

Canon F-1



INSTRUCTIONS

Welcome to the large family of well satisfied F-1 owners. The F-1, along with its seemingly endless array of features and accessories for use in the home, the laboratory or for professional work, is the product of many years of studious research coupled with the development of Canon's superior camera technology. The Canon F-1 epitomizes the high quality and performance standards that Canon prides itself in. We at Canon hope that you make the most of your new F-1 and have many rewarding experiences with your F-1 system.

Before Using...

Please read this instruction booklet thoroughly, familiarizing yourself carefully with the F-1, master the basic functions of the camera completely and you will be ready to fully utilize your new F-1.



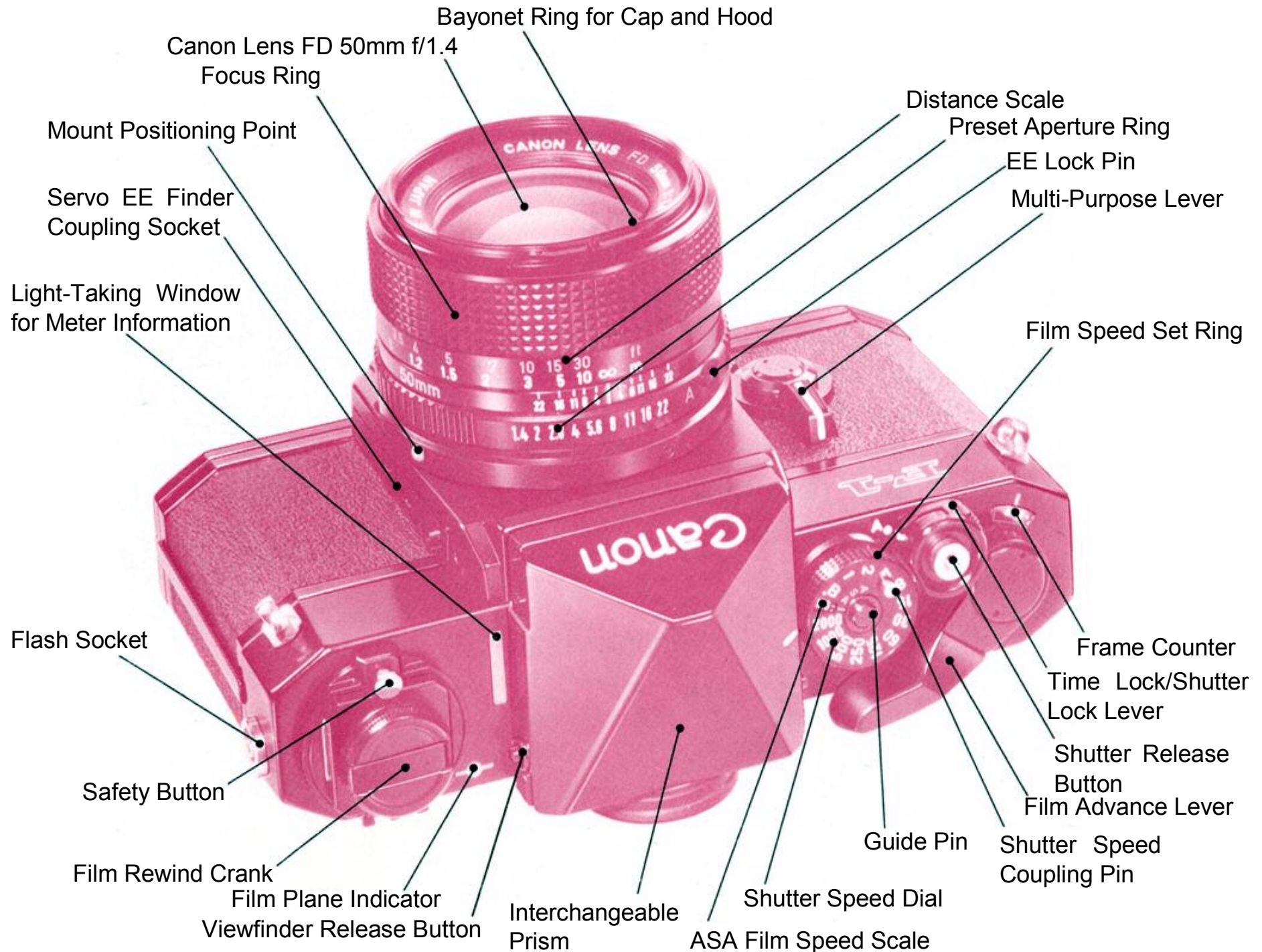

The system built around the F-1, from its initial stages, is designed to satisfy all possible photographic needs. Both versatility and variety were prime concerns for Canon's planning and designing staff. The system's ten thousand component parts are all built with a degree of accuracy which the complete interchangeability of the system requires. Furthermore, tests have demonstrated that the reliability of the Canon F-1 and its accessories is to an extent as of yet unmatched by any other product in the photographic industry. The F-1's accessories, including powerful motor drive systems, a unique Servo EE Finder, the Booster T Finder for dim light situations, the Film Chamber 250 and the incomparable FD series of interchangeable lenses, lend the versatility to the F-1 that makes the F-1 an all-embracing photographic system.

Contents

| | |
|--|--------------|
| Technical Data | 6 |
| Uses of Lenses | 10 |
| Mercury Battery Loading and Checking | 16 |
| Film Loading | 19 |
| Film Winding | 22 |
| Shutter and Aperture Adjustment | 24 |
| Manual Diaphragm Control | 27 |
| Using the Built-in Exposure Meter | 30 |
| Exposure Settings | 32 |
| Coupling Range of Built-in Exposure Meter | 35 |
| Holding the Camera | 36 |
| Viewing and Focusing | 37 |
| Film Rewinding | 40 |
| Lens Signal Coupling | 42 |
| Flash Photography | 47 |
| Multiple Exposures | 49 |
| Using the Self-Timer | 50 |
| Removing the Bottom and Back Covers | 51 |
| Accessories for the F-1 | 53-59 |
| Motor Drive System and Power System | 54 |
| Viewfinder System | 56 |
| Close-up, Photomacrography and Photomicrography | 58 |
| Filters | 60 |
| Data Imprinting System and Other Accessories | 61 |
| Proper Care of the Camera | 63 |

Technical Data

- Type: 35mm single-lens reflex camera with focal plane shutter. Picture size: 24 x 36mm.
- Interchangeable Lenses: Canon FD series lenses with aperture signal lever. FL and R series of lenses are also compatible.
- Standard Lens: Canon FD 55mm f/1.2 S.S.C., FD 50mm f/1.4, or FD 50mm f/1.8.
- Viewfinder: Removable pentagonal prism viewfinder. Interchangeable with Servo EE Finder, Booster T Finder, Speed Finder, Waist-Level Finder.
- Viewfinder Attachments: Angle Finders A2 and B, Magnifier R, Dioptic Adjustment Lenses, Eyecup R, Rubber Eyepiece Ring.
- Focusing Screen: Fresnel lens, standard focusing glass with split-image/microprism range-finder and eight other interchangeable types. With metering beam-splitting condenser.
- Field-of-view: 97% of actual picture area. 0.77X magnification with standard 50mm lens at infinity.
- Finder Information: Meter needle and aperture needle, outside shutter speed coupling range indicator, stopped-down metering and battery check, shutter speed scale, metering limit marks.
- Dioptic Adjustment Lenses: Viewfinder with lensless ring (R-1); interchangeable with R+3, R+2, R+1.5, R+1, R+0.5, R0, R-0.5, R-2, R-3, and R-4 dioptic adjustment lenses.
- Mirror: Quick return mirror with shock-absorbing mechanism. Possible to lock mirror in up-position, requiring manual operation of the aperture.
- Lens Mount: Canon Breech-lock FD mount.
- Function: FD lenses; Pull aperture metering, automatic diaphragm operation. FL lenses; Stopped-down metering, automatic diaphragm operation. R lenses; Stopped-down metering, manually operated diaphragm.
- Shutter: Focal plane shutter using a super thin titanium screen. Designed for elimination of functioning noise. Possible to lock shutter release button.
- Shutter Speed Dial: With shutter scales and ASA film speed scales. Two coupling pins for setting attachments are provided.
- Shutter Speeds: B, 1-1/2000. Multiple series. Equiinterval index. X contact at "60".
- Film Speed Scale: ASA 25-3200
- Self-Timer: Built-in. Activate with shutter release button. Approx. 10 sec. time lag.
- Exposure Adjusting Mechanism: Built-in. Using -a CdS photocell. Coupled to shutter speeds,

film speeds and f/stop. Match needle type, TTL full aperture metering mechanism. Central area metering system, measures 12% of the picture area. Stopped-down metering possible with non-FD lenses. Stop-down lever and index. Locking of the lever possible.

- Exposure Meter Coupling Range: With ASA 100 film, EV 2.5 (f/1.2 at 1/4 sec.) to EV 18 (f/11 at 1/2000 sec.).
- Meter Battery: One 1.35V mercury battery.
- Battery Checker: Built-in.
- TTL Full Aperture Metering System: Servo EE Finder and Battery Case in combination.

Full aperture metering with FD lens.

- Ultra-low Illumination Metering: Metering possible with ASA 100, between EV 15 (f/22 at 1/60 sec.) and EV-3.5 (f/1.2 at 15 sec.), with use of the Booster T Finder.
- Synchronized Flash: FP and X contact. Automatic time lag adjustment.
- Flash Socket: Screw-in/plug-in type.
- Accessory Shoe: Flash Couplers D, L.
- Canon Auto Tuning (CAT) System: Diaphragm control by recharge completion signal and focusing distance signal by using the Speedlite 133D, Flash-Auto Ring A2/B2, Flash Coupler L and the prescribed chrome-mount-ring FD lens.
- Synchronizing Range: FP class: 1/2000-1/125 sec. and 1/30 sec. or slower. Speedlite: 1/60 sec. or slower. M, MF class: 1/30 sec. or slower.
- Film Loading: With multislit film spool.
- Film Winding: Short-stroke winding possible. Single operation 139° winding lever. Play: 30°
- Film Rewinding: Performed by rewind button and crank.
- Multiple Exposure: Possible by operating film rewind button.
- Back Cover: Removable for Film Chamber 250 and Data Back.
- Bottom Cover: Removable for Motor Drive Unit or Motor Drive MF.
- Frame Counter: Additive, self-resetting type activated by opening back cover.
- Size: 99.5x 146.7x49.5mm (3-15/16" x5-3/4" x 1-15/16")
- Weight: Body: 845g (1 lb. 13-13/16 ozs.). With FD 50mm f/1.4. Lens: 1,085g (2 lbs. 6-1/4 ozs.).

Follow these simple steps for Normal photography:

- 1 Load the film. (See pages 19–21.)
- 2 Set the ASA film speed. (See page 31.)
- 3 Wind the film advance lever. (See page 22.)
- 4 Remove the lens cap. (See pages 10-11.)

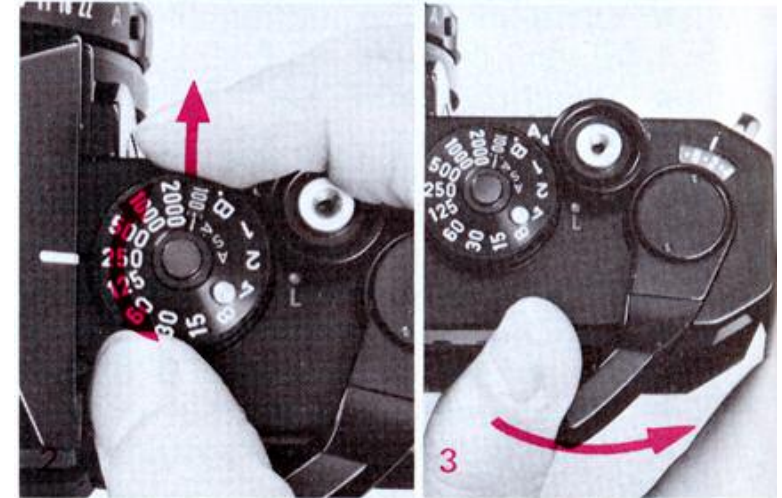
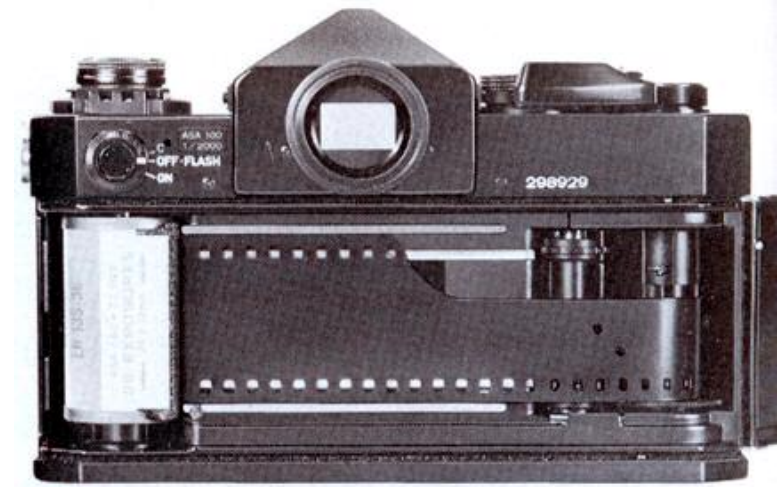

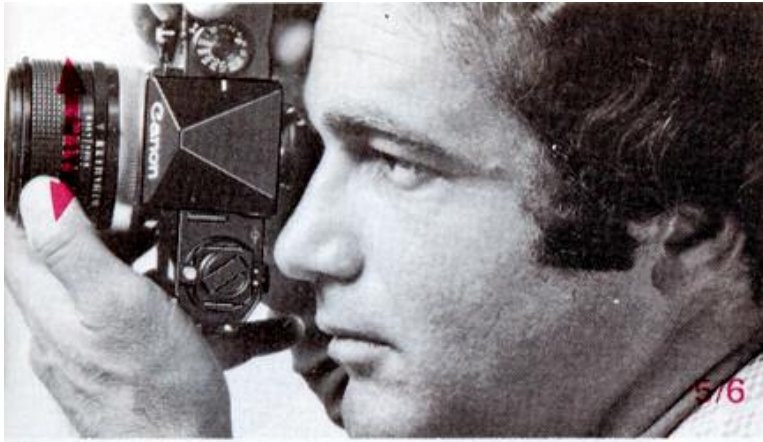

5 Look through the viewfinder and focus.
(See page 37.)



6 Compose the picture.

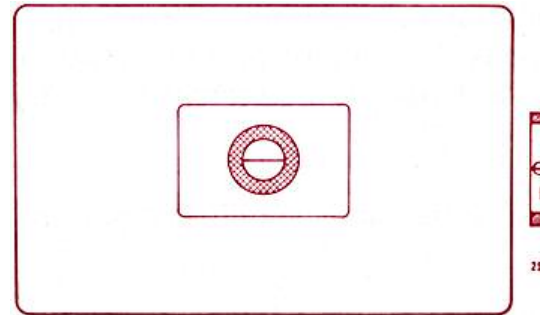

7 Determine the exposure with built-in meter.
(See pages 32-34.)

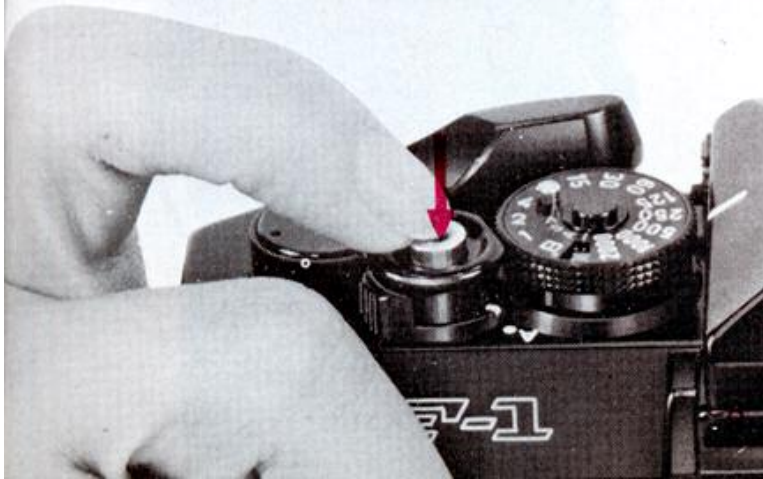

8 Press the shutter release button gently.

Uses of Lenses

Lens Cap and Rear Dust Cap

The front and rear lens caps should always be on the lens when the lens is not on the camera. For protection when the lens is mounted on the camera but not in use, please see to it that the front lens cap is attached.

Lens Cap

Most Canon lenses are provided with a clip-on front lens cap which is easily attached and removed from the front of the lens by pressing in the tabs on both sides of the cap. This type of cap may also be attached to a Canon filter screwed into the lens.

Rear Dust Cap

The rear dust cap must be removed before mounting the lens.

Operation with an FD lens which lacks a chrome Breech-lock mount ring:

The rear dust cap for this type of lens has serrated edges. Do not mount a rear dust cap which lacks the serrated edges.

Removal from Lens

- 1 Turn the cap counterclockwise until it stops.
- 2 Pull the cap out.



Reattachment

- 1 Align the arrow on the cap with the red dot at the rear of the lens.
- 2 In that position, apply slight pressure to the cap and turn it clockwise until it is tight.

Operation with an FD lens which has a chrome Breech-lock mount ring or with an FL lens: Removal from Lens

- 1 Turn the lens' mount ring clockwise until it stops.
- 2 Pull the cap out.

Once the rear cap is removed, the Breech-lock mount ring is locked so that it cannot be turned. (The diaphragm blades are also locked and will not move even if the aperture ring is rotated.)



Reattachment

- 1 Make sure the mount ring is locked so that it cannot be turned.
- 2 Align the arrow on the cap with the red dot on the lens' mount ring.
- 3 In that position, push lightly down on the cap and turn the mount ring counterclockwise until it is tight.

Mounting on the Camera and Dismounting Pre-Mounting Checklist

- 1** Make sure the camera's multi-purpose lever is not set for stopped-down metering (see p. 33). If it is, a red warning dot will appear beside the coupling lever inside the camera body.
- 2** Make sure the automatic aperture lever at the rear of an FD lens is not set for manual diaphragm control (see p. 27).
- 3** Remove the lens' rear dust cap.
- 4** Remove the camera's body cap.





Lens Release Button

Procedure for an FD lens which lacks a chrome Breech-lock mount ring:

Mounting

- 1 Align the projecting red mount positioning point with the red dot above the camera mount.
- 2 In this position, apply slight pressure to the lens, and simply rotate the whole lens clockwise until it stops and the lens release button pops out with a click.

Do not press the lens release button while mounting the lens. Only when this button pops out can you be sure that the lens is properly mounted and that it will function properly. It is also possible to mount this type of lens when it is not perfectly aligned with this camera.

To facilitate mounting when it is very dark or when you are in a great hurry, the mount positioning point is rounded. Simply find this point with your finger and align it as closely as possible with the red dot on the camera. Turn the lens slightly back and forth while applying slight pressure until it drops into position and continue with step 2 above. Excessive sloppiness will make mounting impossible; take care to be as accurate as possible.

Dismounting

- 1 Turn the lens counterclockwise until it stops while pressing the lens release button.
- 2 Pull the lens out.

When the lens is dismounted, the diaphragm blades are locked in a half-closed position and will not move even if you turn the lens aperture ring.

Procedure for an FD lens which has a chrome Breech-lock mount ring or for an FL lens: Mounting

- 1 Make sure the Breech-lock ring is locked so that it cannot be turned.
- 2 Align the red dot of the Breech-lock ring with the red dot on the camera body above the camera mount.
- 3 In this position, fit the rear of the lens into the camera body and turn the Breech-lock ring clockwise until it is tight.

Dismounting

- 1 Turn the Breech-lock ring counterclockwise until it stops.
- 2 Pull the lens out from the camera body.

When removing a lens, take special care not to damage the protruding pins and levers on the rear. With the exception of the Fish-eye 7.5mm lens, always put a lens down with the rear facing up.

For more information on general use and care of the lens, please see the lens instruction booklet.

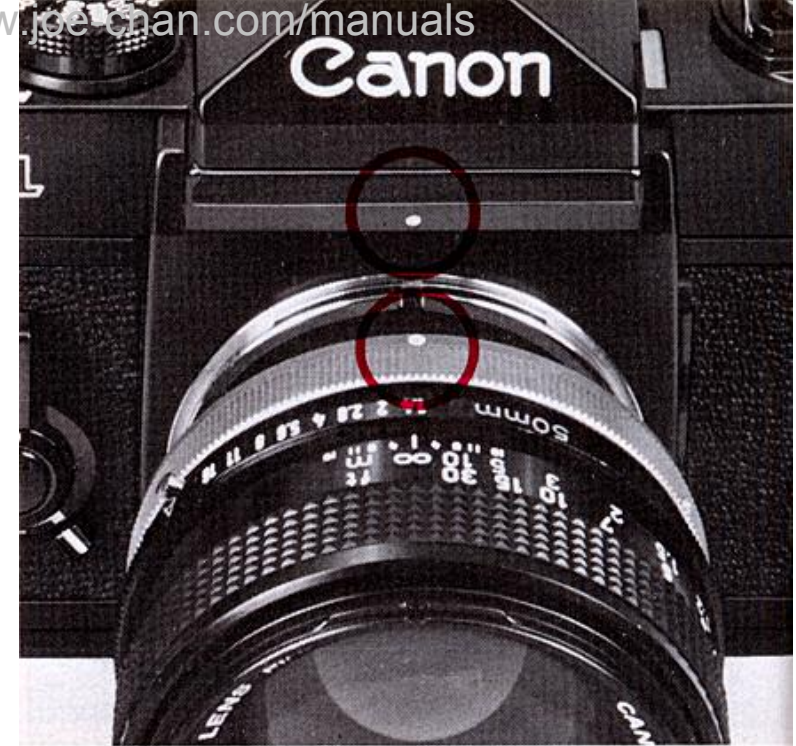



Note

On the aperture ring of an FD lens there is a green "A". The aperture ring can be turned to or from this mark by pressing the EE lock pin. Setting the lens to "A" permits AE photography when the accessory Servo EE Finder is mounted on the F-1. At any other time the aperture ring should be off "A". Please note that some early FD lenses have a green circle instead of "A" and that the aperture ring can be turned freely to that mark since these lenses lack an EE lock pin.

Neckstrap

Thread the tips of the neckstrap through the corresponding rings on the camera so that the tips are on the inside. Then adjust the strap to the length most comfortable for you.

Eyecup 3R

The F-1's rubber eyepiece ring can be replaced by this accessory eyecup. The eyecup is attached by snapping it into the eyepiece grooves after removal of the screw-in eyepiece ring. Its use is not mandatory, but viewing with it may be more comfortable, and it helps block extraneous light from entering the viewfinder.

Mercury Battery Loading and Checking

The built-in exposure meter of the Canon F-1 functions only when the mercury battery is properly loaded.

1 Insert a coin into the groove of the battery compartment cover and turn it to the left to remove the cover.

2 Insert the battery into the compartment with negative pole first.

3 Replace the compartment cover and turn to the right to tighten.

- Before inserting the battery, wipe off fingerprints or stains on the battery poles with a dry cloth. Unclean poles may cause corrosion and damage the camera.
- A 1.35V H-D mercury battery should be used — a Mallory PX-625 or Eveready EPX-625 is recommended. Do not use 1.4V mercury batteries.
- Be sure to insert the battery in the correct direction. Otherwise, the meter will not function properly and the cover cannot be screwed-in.
- If the camera will not be used for an extended length of time, the battery should be taken out of the battery compartment to prevent possible damage to the terminals from battery corrosion.

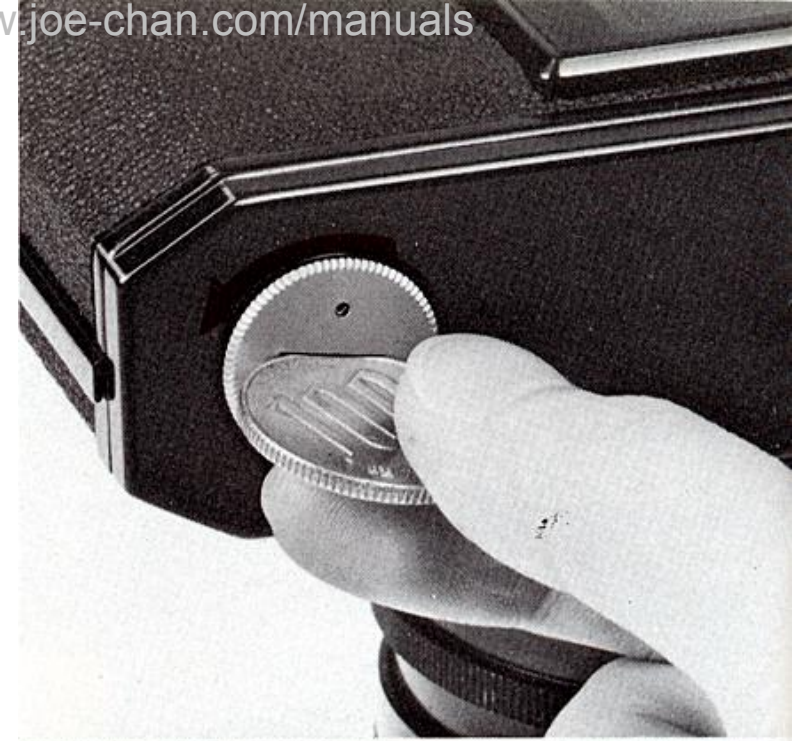

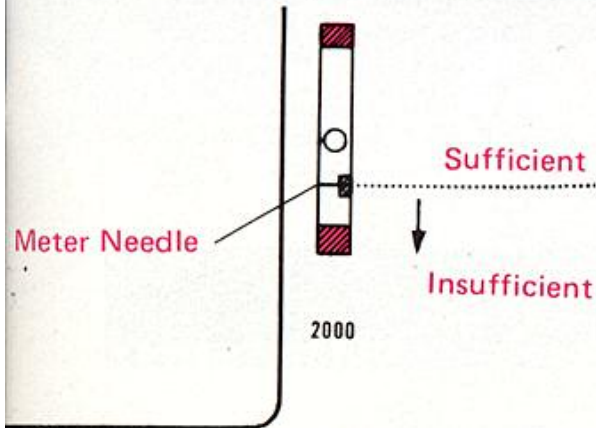
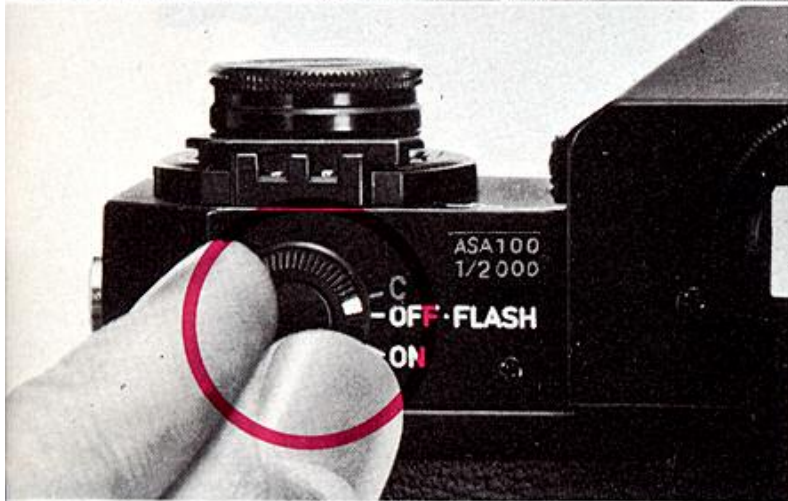

Battery Check

Check the mercury battery after loading it. Especially when loading a new battery, be sure to check the power level.

1 Set the film speed scale at ASA 100 and the shutter speed dial at "2000". To set the film speed, lift up the outer ring on the shutter speed dial and turn. (See page 31.)

- A positive check cannot be made if other settings are used.

2 Turn the meter switch, situated on the back side of the camera near the film rewind crank, to the "C" index mark.

3 If the meter needle inside the viewfinder swings into the meter index, the battery has sufficient power. If the needle stays below the meter index, the voltage is insufficient and the battery must be replaced.

- Life of the battery in normal use is approximately one year.

4 When using the camera, be sure to turn the meter switch to "ON".

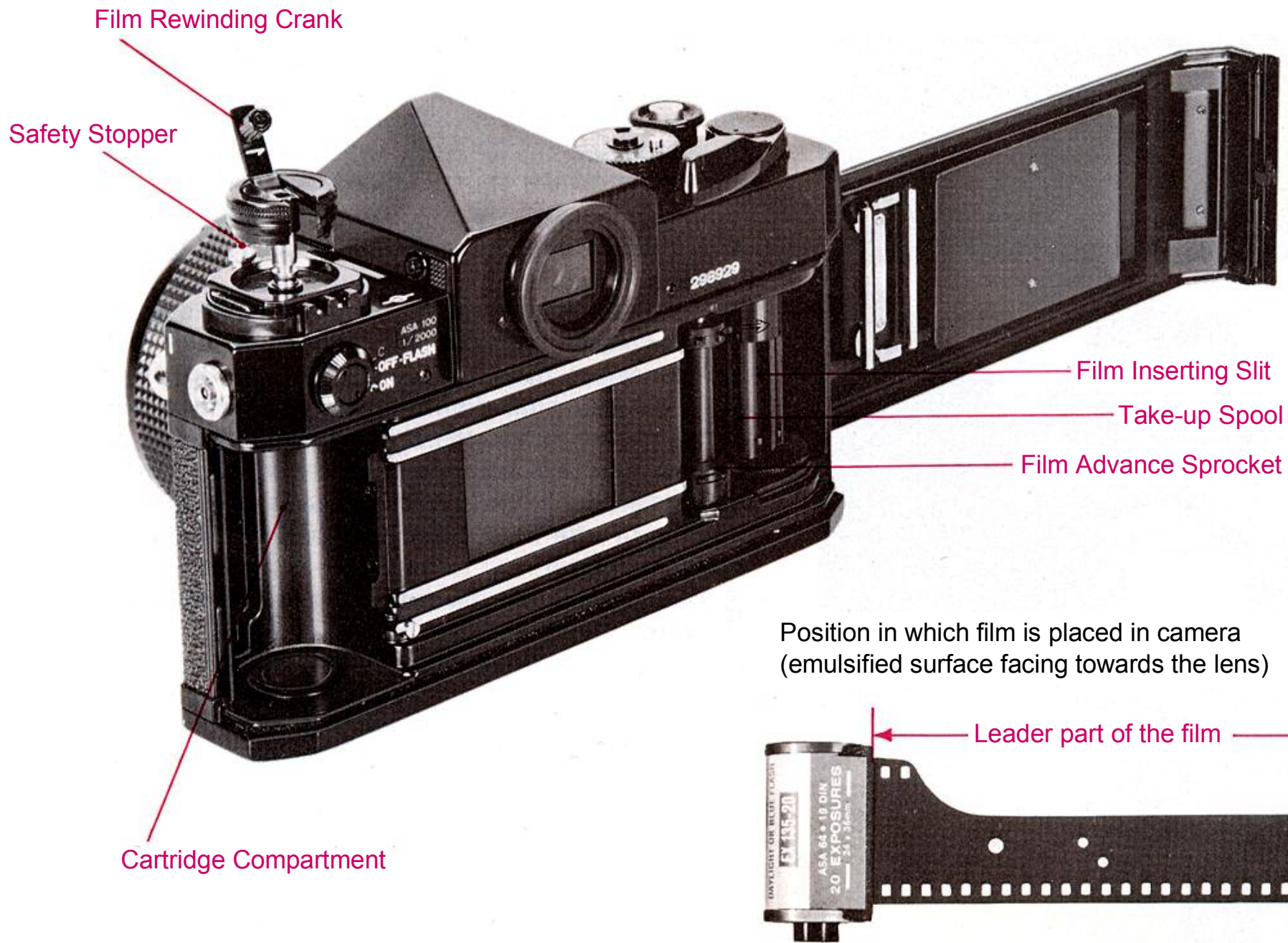

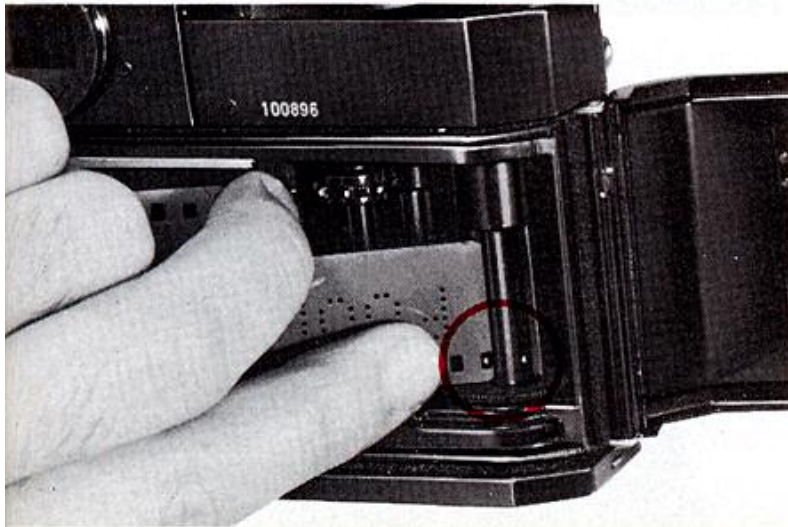
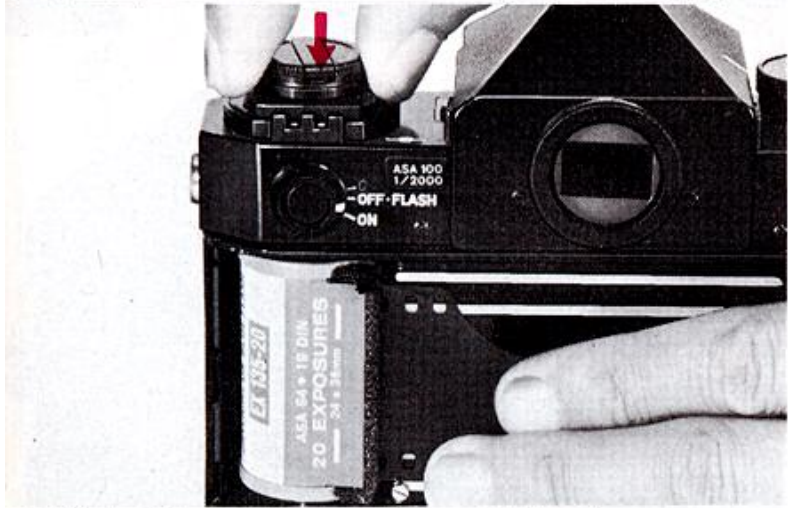
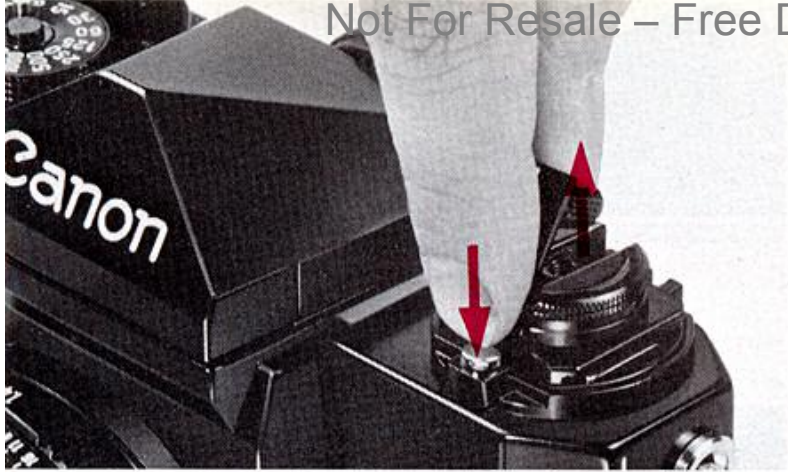

Film Loading

The Canon F-1 accepts color or black and white film in standard 35mm cartridges. When loading and un-loading film, avoid direct sunlight.

1 Pull up the film rewind crank as far as possible while pressing the safety button. The camera's back cover will pop open.

2 Open the cover fully. Place the film cartridge in the film compartment so that the emulsion faces the lens when the film is unwound as illustrated on page 18. Push the film rewind crank down. The crank fork will slip into the film cartridge. In case the crank does not fully return, turn it slightly to the left or right.

3 Pull the film leader across the camera and insert the film tip into the slit of the film take-up spool.

- 4** Turn the film advance lever and wind the film around the film take-up spool.
- 5** Check to insure that the teeth of both the take-up spool and the film advance sprocket engage the perforations in the film.
- 6** Close the back cover. If the film is slack, the cartridge will rise and the back cover will not close.
- 7** Leave the lens cap on and take two blank shots, each time turning the film advance lever and releasing the shutter. The frame counter will advance from the "S" mark to "0". With one more advance, the camera will be ready for the first shot.

Checking Correct Film Loading

The film is properly loaded and advanced if the film rewind crank rotates when you wind the film advance lever. If the film rewind crank does not rotate, take out the film and reload it.

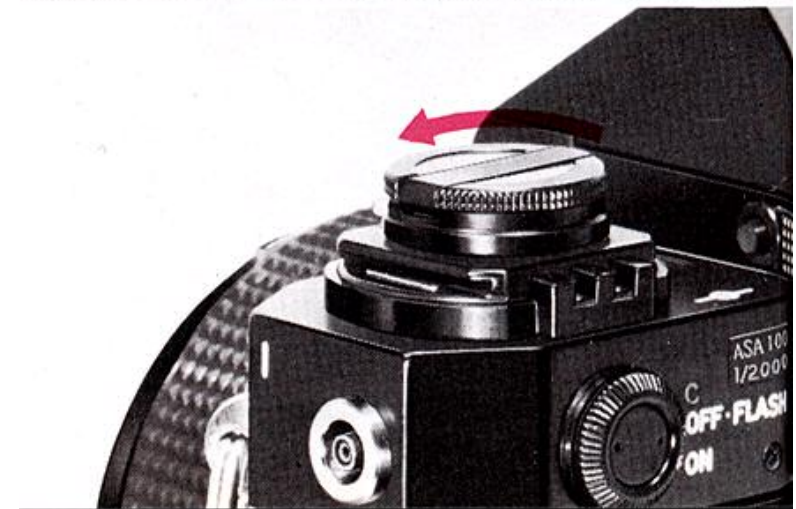
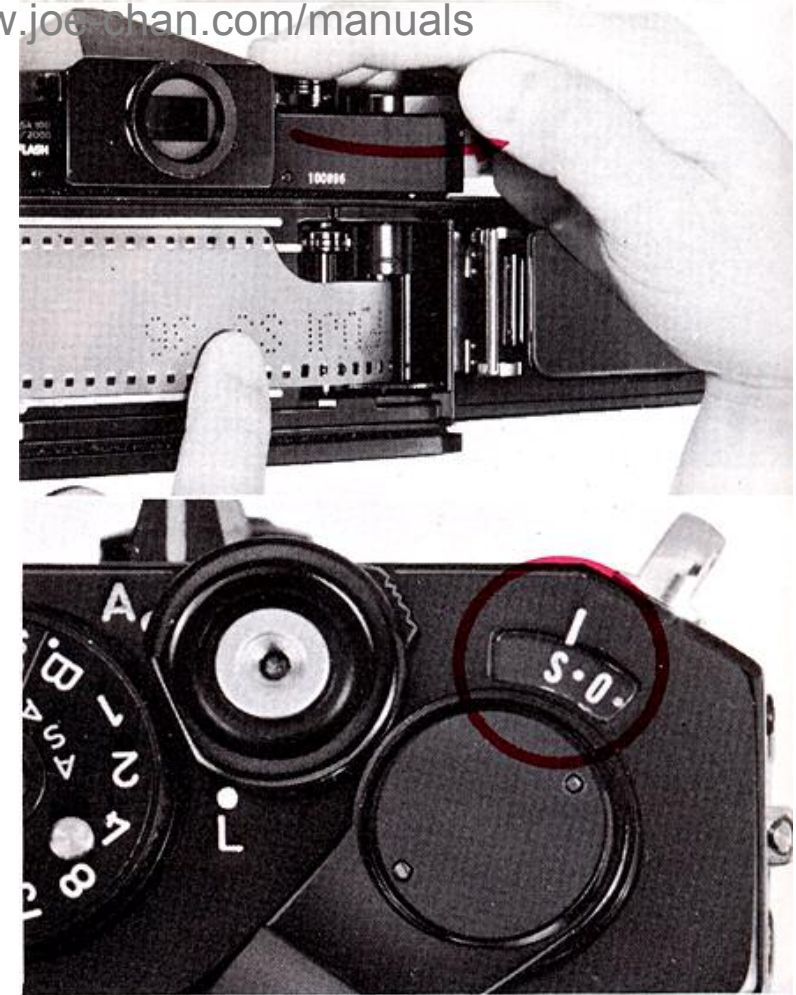

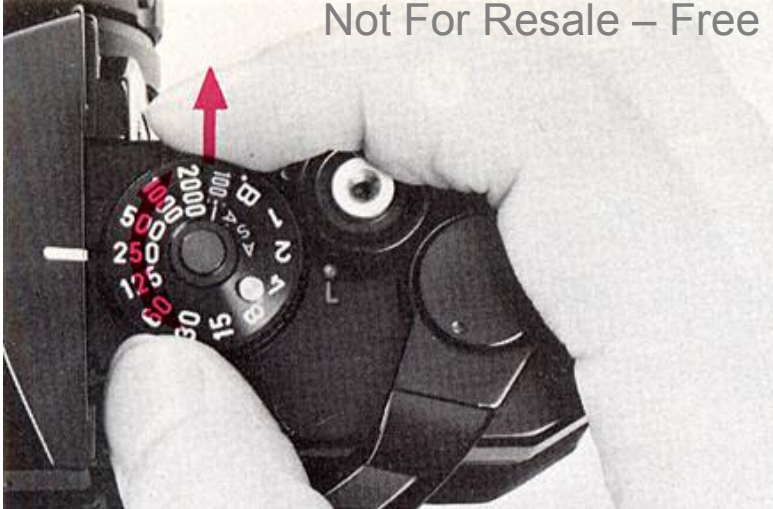

Setting the Film Speed

When loading the film, be sure to set the film speed scale at the proper position.

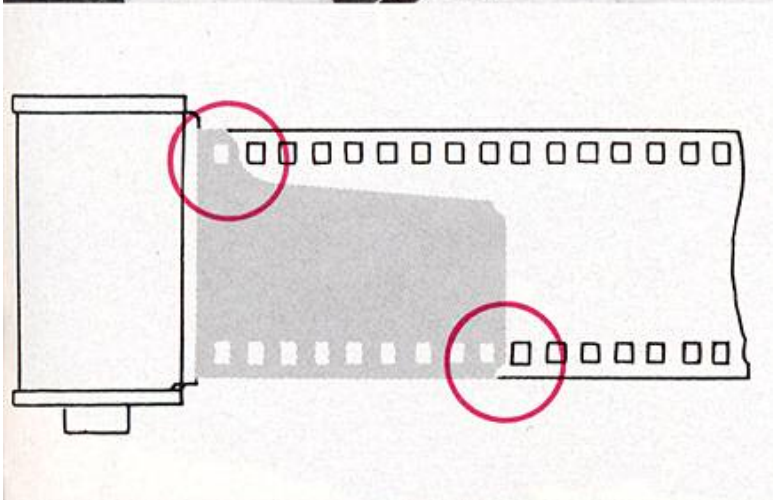

Repacking a Bulk-Loaded Film

If you are using film that has not been wound commercially, be sure to trim the tip of the lead between perforations.

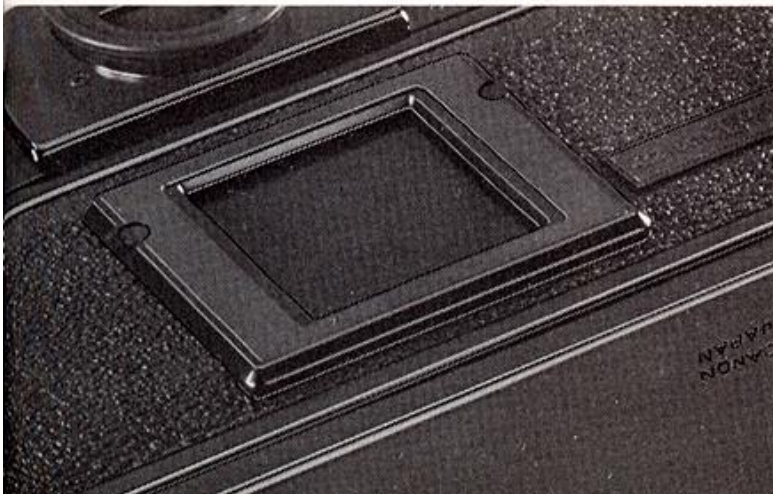

Memo Holder

The memo holder on the camera's back cover is useful for keeping data like film speed, location, shooting. For example, after tearing off the end of the film box which specifies the type of the film being used, it can be inserted into the memo holder as a constant reminder.

Film Winding

The film advance lever winds the film, cocks the shutter, and prepares the diaphragm and mirror for the next shutter release all in one motion.

1 Turn the film advance lever until it stops. The film will be advanced one frame and the shutter cocked. The frame counter is simultaneously advanced to the next number.

2 When the shutter release button is pressed, the mirror flips up, the diaphragm closes down to the preset f/stop and the shutter operates. The advance lever can then be wound for the next frame.

- Be sure to set the shutter lock lever at "A".
- Winding may be accomplished by moving the lever with several short strokes.
- If the shutter does not function, check to make sure the winding process is completed as the shutter will not function unless winding is completed.

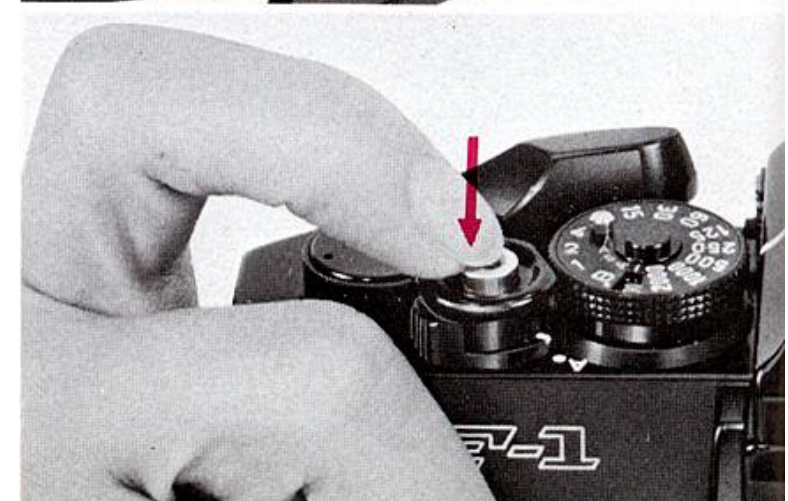

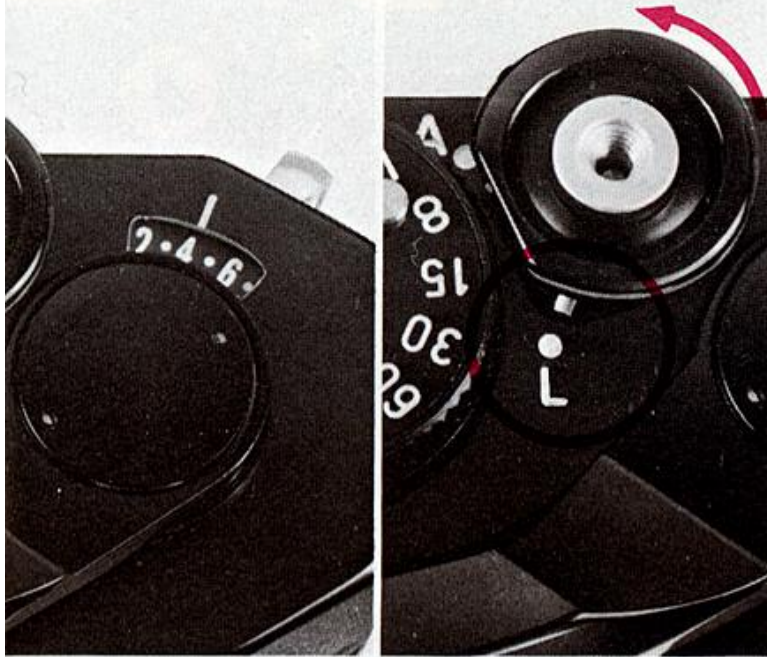

Frame Counter

Each winding will advance the number of the frame counter, indicating the number of pictures taken. When the back cover is opened, the counter automatically returns to the starting position "S".

Safety Device for Shutter

When the shutter lock lever around the shutter release button is turned to the "L" position, the shutter button is locked and will not move. This device is especially useful in preventing an accidental shutter release of a wound camera.

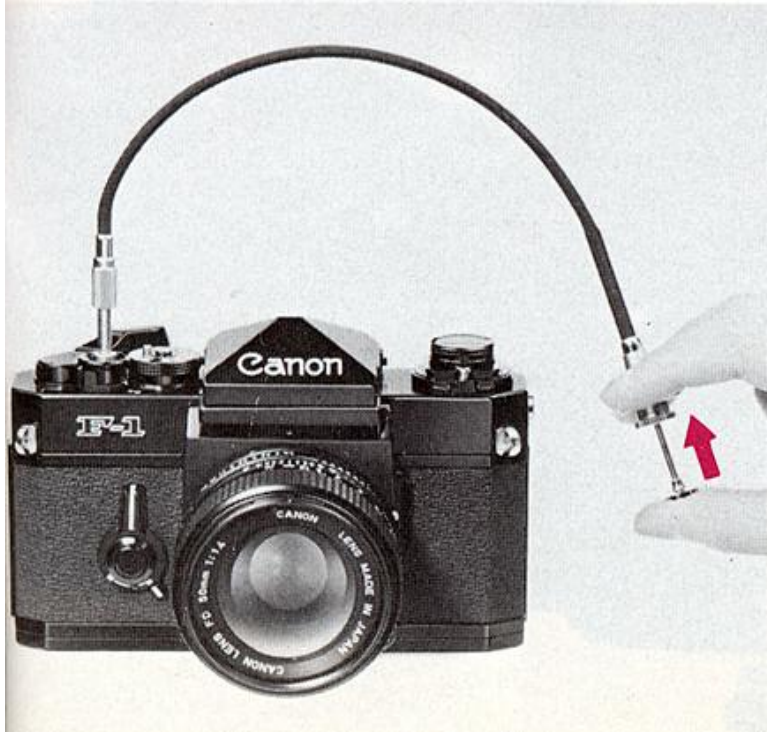

Attaching the Cable Release

The optional Canon Cable Release can be attached to the F-1 by screwing it into the threaded hole in the center of the shutter release button. Even if the shutter lock lever is at the "L" position, the shutter will operate when using the cable release.

Shutter and Aperture Adjustment

Exposure is adjusted by the shutter speed and the aperture. The shutter speed controls the exposure time and the aperture controls the amount of incoming light.

Shutter Speed Dial

Adjust the shutter speed by turning the shutter speed dial to the desired speed as indicated by the numbers on top of the dial. The dial cannot be turned between "2000" and "B". The numbers on the shutter speed dial correspond to shutter speeds between 1/2000 of a second and one second counting counterclockwise on the dial. The "B" position, indicating bulb exposure, is used when making exposures of more than one second. Thus, when set at "B", the shutter remains open as long as the shutter release button is depressed.

- Be sure to set the dial at one of the click-stop positions. At the "B" position, adjust it to the white dot just below "B".
- When it is necessary to make a time exposure, first set the shutter speed dial at "B", Keep the shutter release button depressed and turn the time lock lever to "L". Thus, the shutter will remain open even if the finger is removed from the button. When the lever is returned to "A", the shutter closes.
- Time exposure is also possible by using a lockable cable release.
- It is possible to perform extended exposures of up to

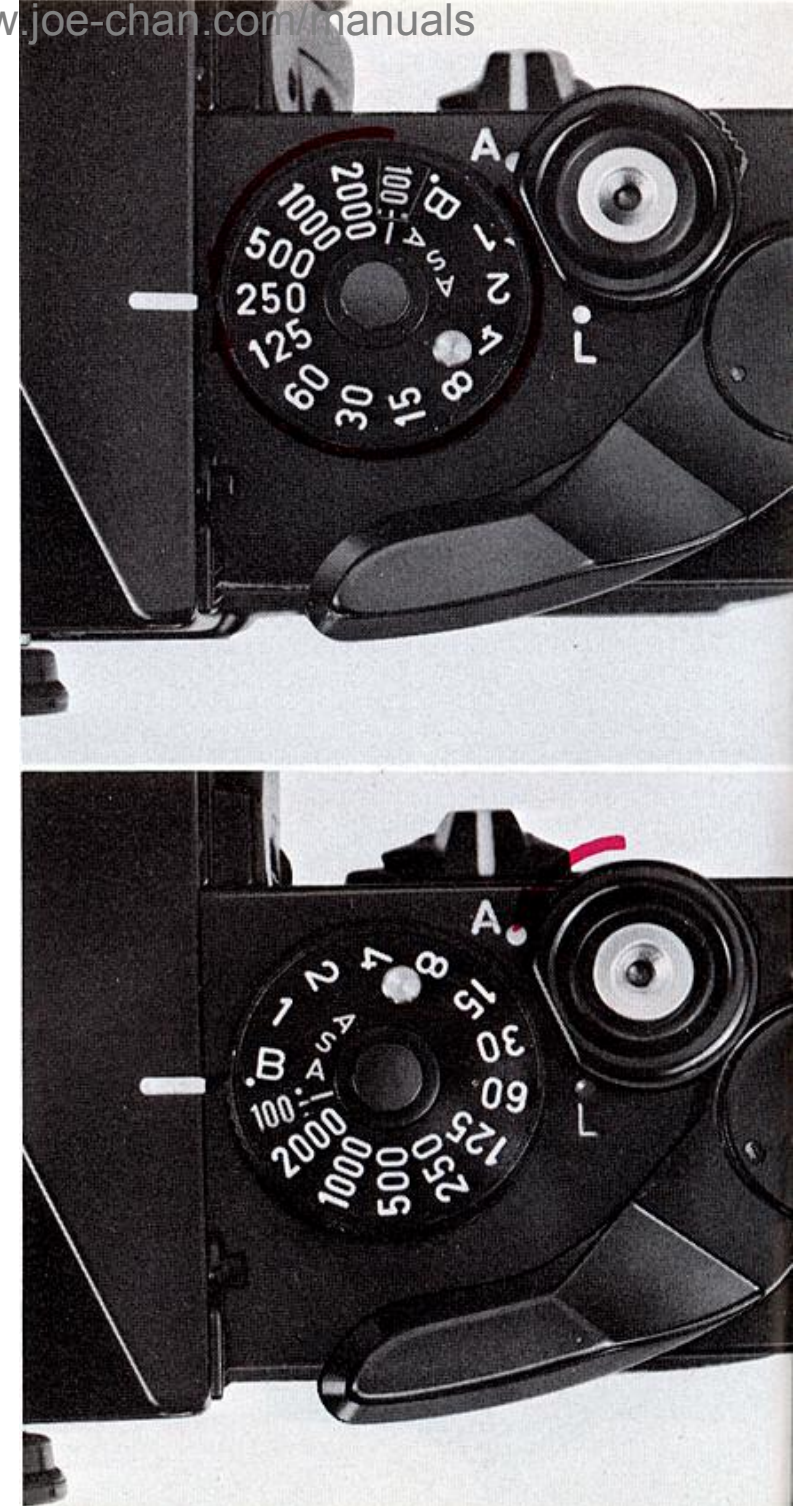

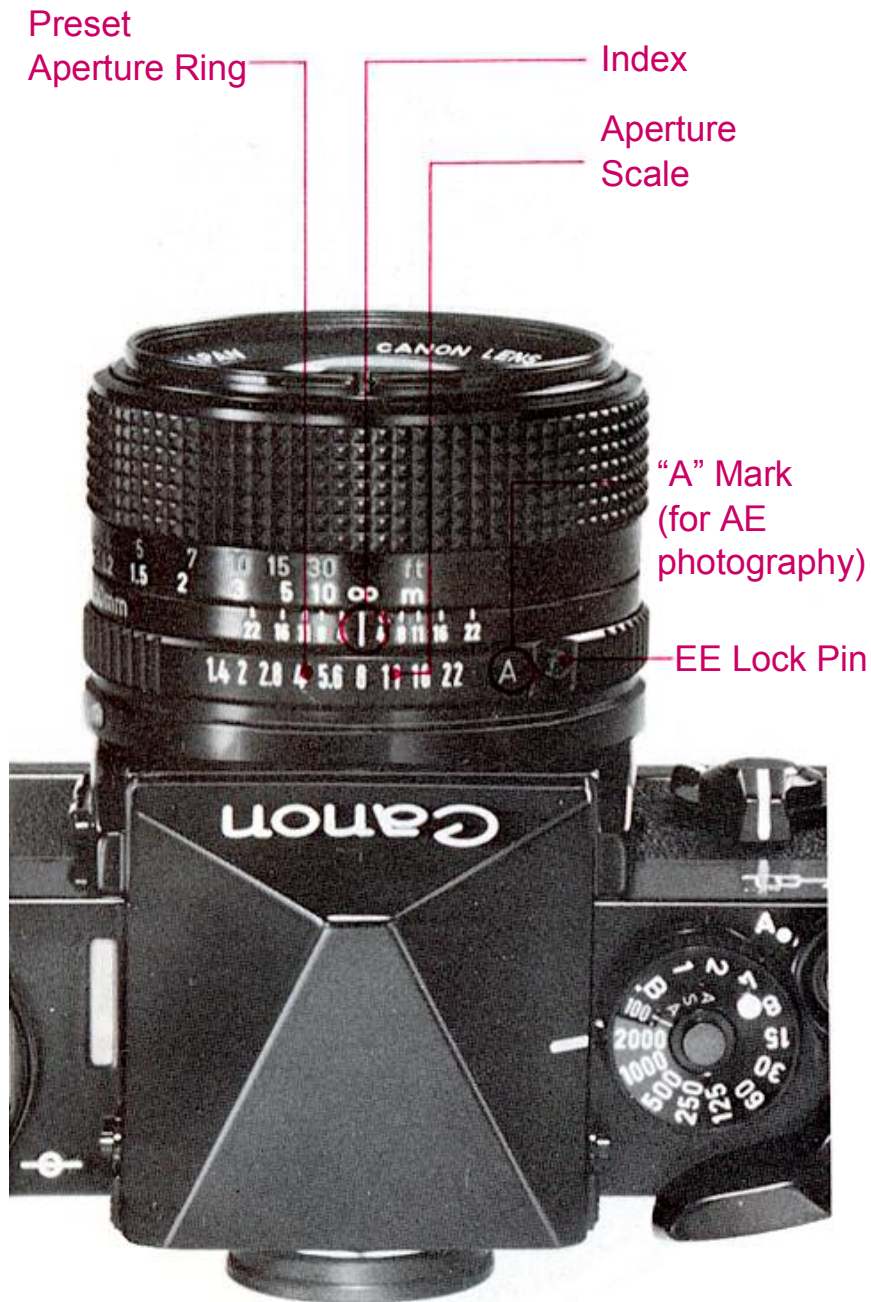

30 seconds by using the optional Booster T Finder, a super sensitive meter finder for measuring subjects under dim light.

- The "60" position is the X synchronization speed, the highest shutter speed which can be used with electronic flash units such as a Canon Speedlite, and the fastest shutter speed at which the entire film area is exposed at once. Although 1/60th of a second does not seem to be a really fast shutter speed, the effective exposure time is equivalent to a flash of 1/1000th of a second or faster. This speed allows the very brief duration of the electronic flash to expose the entire film.

Aperture

Incoming light and depth-of-field are adjusted by turning the aperture ring to the desired f/stop.

A number scale, which has become the international standard, has been devised to express the size of the aperture in relation to the focal length of the lens whereby the aperture size is divided by the focal length of the lens until the numerator of the resulting fraction is reduced to one. Thus, the magnitude of these fractions is inversely related to the size of the aperture, i.e., a larger number on the scale signifies a smaller aperture while a smaller number signifies a larger aperture. Since both circular area and linear dimension are involved in the computation of this scale, an aperture, usually termed a full f/stop, is one-half or twice as large as the adjacent apertures indicated by the scale.

- The aperture ring of most Canon FD lenses is equipped with click-stops for full and 1/2 f/stops, but can be set between these click-stops.
- The maximum aperture of a lens may not be one included by the international standard. If it is not, the second f/stop will not designate an aperture one-half as small as the maximum f/stop.
- The relation between the aperture and the amount of light entering, using f/2 as the base, is as follows:

f/stops*:

1.2 **1.4** 1.8 **2** **2.8** 3.5 **4** **5.6** 8 **11** **16** **22**

Exposure Ratio:

3 2 1.25 1 1/2 1/3 1/4 1/8 1/16 1/32 1/64 1/128

*f/stops on the international scale are in heavy type.

Presetting of Aperture

Set the aperture ring to the desired f/stop. The diaphragm will close to the set f/stop only for the instant that the shutter is released. Thus, for example, with FD lenses, the subject can always be seen through the viewfinder at the full aperture opening even after the f/stop has been set by the aperture ring.

The FD lens has only one aperture ring. When this lens is mounted on an F-1 or FTb camera body, the diaphragm can be operated manually by pushing the multi-purpose lever. The aperture can then be closed down to any desired f/stop by turning the aperture ring. When the lever is reset to its original position, the diaphragm returns to its maximum opening.



FD 50mm f/1.4



Automatic Aperture Lever

Manual Diaphragm Control

The insertion of manual accessories or a macrophoto coupler between the camera and an FD lens requires setting the lens for manual diaphragm control before stopped-down metering is possible. The instructions for the various accessories involved will tell you whether or not this is necessary.



All FD lenses which lack a chrome mount ring, with the exception of the Macro lenses, are set for manual diaphragm control as follows:

1 Before mounting the lens, insert the hole of the accessory manual diaphragm adapter over the tip of the automatic aperture lever at the rear of the lens. Push the lever to the right and lower the adapter into the groove to lock the lever in that position.

2 Mount the lens onto the accessory. The diaphragm will now open and close as the aperture ring is rotated.

When the manual diaphragm adapter is attached on the rear of one of these lenses, never mount the lens directly on the camera or directly on accessories designed for automatic diaphragm control, such as the Auto Bellows or Bellows FL."



Manual Diaphragm Adapter





Automatic Aperture Lever



Manual Aperture Lock Lever

Automatic Aperture Lever

All chrome-mount-ring FD lenses and FD macro lenses are set for manual diaphragm control as follows:

1 Before mounting the lens, push the automatic aperture lever at the rear of the lens to the right where it automatically locks.

2 Mount the lens onto the accessory as usual. The diaphragm will now open and close as the aperture ring is rotated.

Some of these lenses have an additional lock lever. With these lenses, the automatic aperture lever must be pushed fully to the right and the lock lever pushed to "L" to hold the automatic aperture lever in that position.

When using a macrophoto coupler, the Macro Hood must also be mounted onto the rear of the lens.

You may avoid setting the lens for manual diaphragm control when using manual accessories or a macrophoto coupler by attaching the Canon Macro Auto Ring and / or Double Cable Release (optional accessories).

Be sure to reset the automatic aperture lever to its normal position before using the lens once more in direct contact with the camera. In the case of a lens with a lock lever, switch it back to the position of the white dot.

Using the Built-in Exposure Meter

The Canon F-1 provides the most accurate light measurement possible with its unique TTL (Through-The-Lens) system. The built-in exposure meter, which is of match needle type, is coupled to the shutter speed dial and preset aperture ring.

The CdS photocell of the exposure meter is placed in the position closest to the beam-splitting condenser lens. The central area metering system enables accurate measurement of the main subject even in back lighting conditions. The rectangular frame in the viewfinder represents the light measurement area of the CdS photocell. Place the main subject within this frame and measure the intensity of light so as to obtain the proper exposure.

- The correction of the full aperture opening of the lens is performed automatically. Therefore, the operation does not change regardless of the speed of the lens used. An FL lens can be used only with stopped-down metering.
- Due to the characteristics of the CdS photocell, the movement of the meter needle may occasionally be slow at low light intensities.
- When not using the camera, set the meter switch at "OFF" or attach the lens cap so as to prevent unnecessary consumption of the mercury battery.
- Metering at "B" on the shutter speed dial is not possible with the built-in exposure meter.

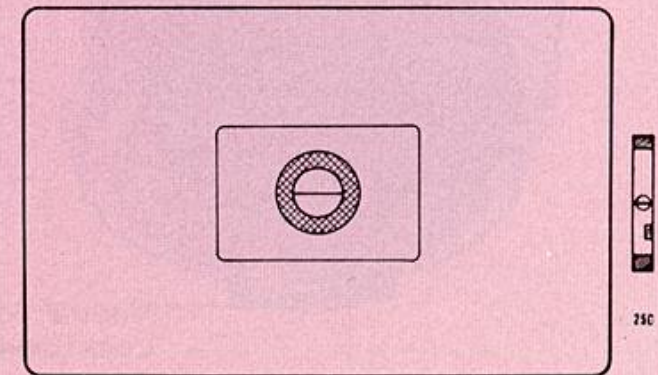
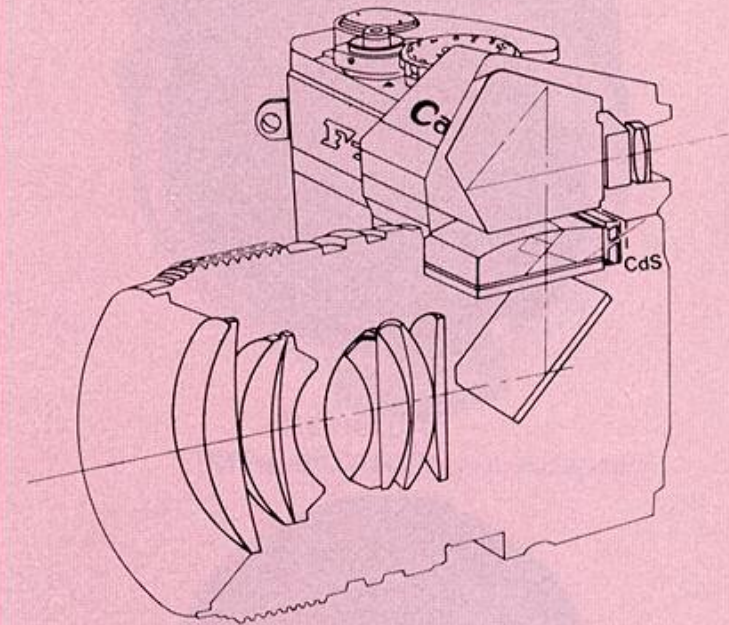

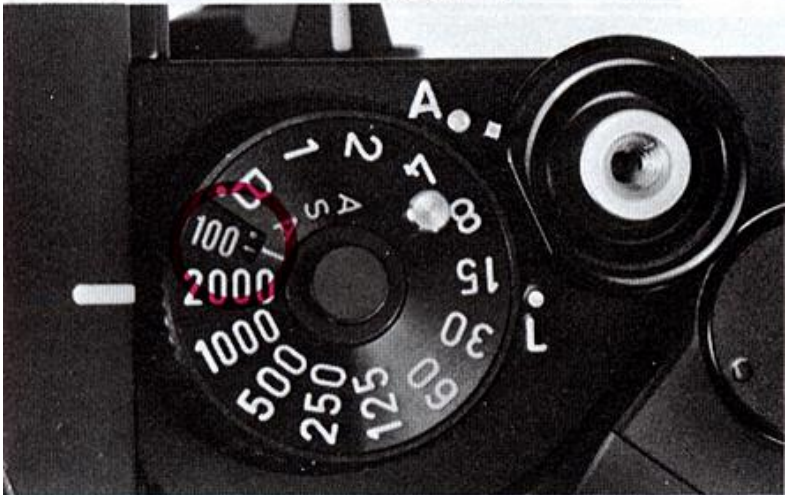
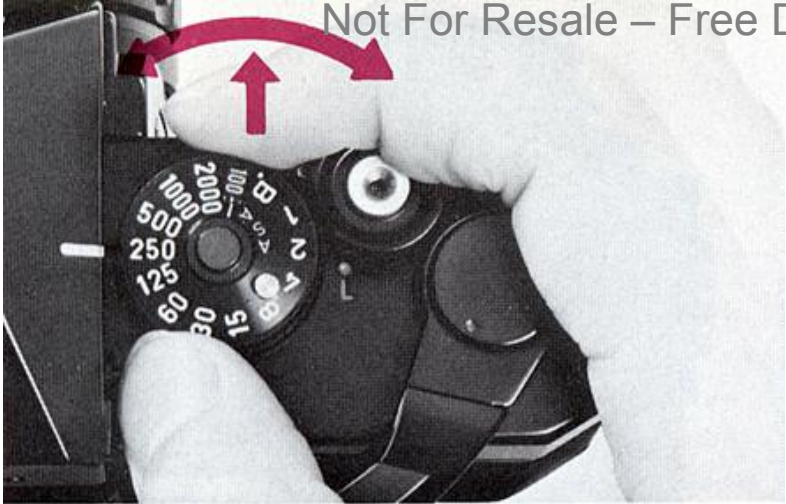

Film Speed Setting

Set the film speed according to the ASA of the film being used. The ASA of a film is normally shown on the film box cover or explanatory sheet. Lift and turn the film speed ring which is around the shutter speed dial. The ASA number of the film will appear in the window on the shutter speed dial.

The ring cannot turn any further counterclockwise than "25". On the other hand, it cannot turn any further clockwise than "3200."

- The following film speeds may be used:

| | | | | | | | | | | | | | | | | |
|-----|--------|--------|--------|--------|-------|-------|-------|-------|-------|-------|---|---|-----|---|---|-----|
| | (32) | (40) | (64) | (80) | (125) | (160) | (250) | (320) | (500) | (640) | | | | | | |
| ASA | 25 | • | • | 50 | • | • | 100 | • | • | 200 | • | • | 400 | • | • | 800 |
| DIN | 15 | • | • | 18 | • | • | 21 | • | • | 24 | • | • | 27 | • | • | 30 |
| | (16) | (17) | (19) | (20) | (22) | (23) | (25) | (26) | (28) | (29) | | | | | | |
| | (1000) | (1250) | (2000) | (2500) | | | | | | | | | | | | |
| | • | • | 1600 | • | • | 3200 | | | | | | | | | | |
| | • | • | 33 | • | • | 36 | | | | | | | | | | |
| | (31) | (32) | (34) | (35) | | | | | | | | | | | | |

(Figures in parentheses represent intermediate film speeds.)

Exposure Settings

Full Aperture Metering

Full aperture metering can be performed with FD lenses which have an aperture signal lever and pin.

- 1 Set the meter switch at "ON".
- 2 Set the shutter speed dial at the desired speed.
- 3 Face the camera towards the subject, look into the viewfinder, and check the needles in the meter

4 reading window.

Turn the aperture ring until the meter needle bisects the aperture metering circle in the meter. If this adjustment cannot be made, a different shutter speed must be used.

- The meter needle is coupled to the film and shutter speeds and moves vertically according to the brightness of the subject. The meter needle moves downward when the shutter is set at high speeds and upward when it is set at low speeds. When the shutter is set at a slow speed outside the coupling range (slower than 1/2 sec. with ASA 100 film), the meter window turns red, and metering will become impossible even if the aperture is changed. When the window turns red and metering cannot be performed, use high-speed film or the optional Booster T Finder. Refer to "Coupling Range of Built-in Exposure Meter" on page 35.

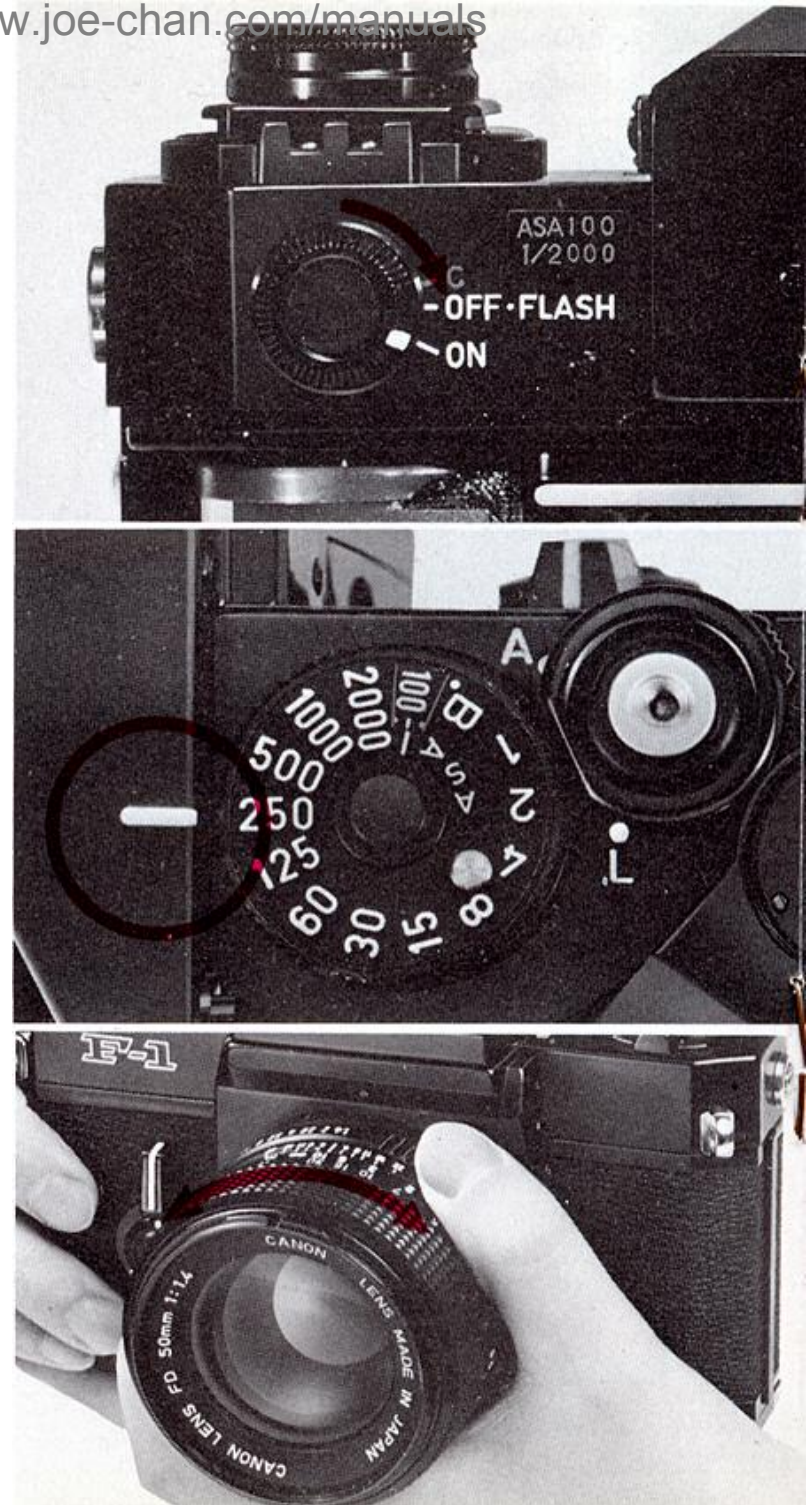

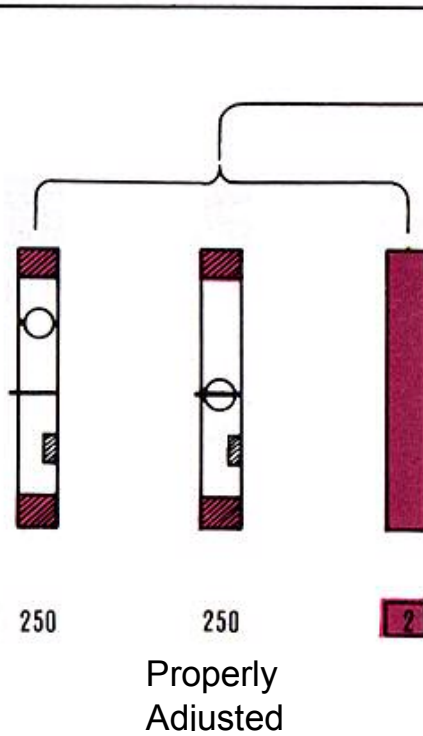
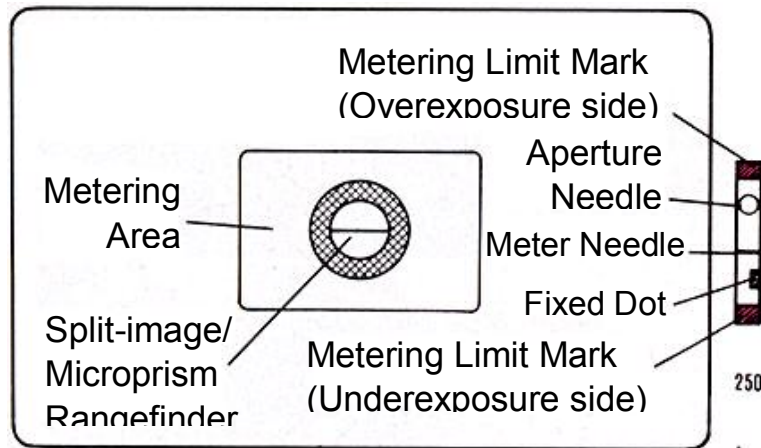

- Select a faster shutter speed when the meter needle swings all the way up, and a slower speed when it swings all the way down.
- The circular aperture needle is coupled to the aperture ring of the FD lens. The movement range of the aperture needle inside the meter reading window changes according to the lens speed. Thus, it will not always move vertically the full length of the meter reading window.
- The "A" mark on the aperture ring is only used with the Servo EE Finder or the Canon AE cameras.
- If you prefer to set the f/stop first, turn the shutter speed dial and bi-sect the aperture metering circle with the meter needle.
- Since the shutter speed dial cannot be set at intermediate positions, the shutter speed priority method is recommended when exposure accuracy is a crucial factor.

Stopped-down Metering

Whenever using an FL or other non-FD lens, such as the TS 35mm or Fisheye 7.5mm lens, on this camera, stopped-down metering is necessary. This means that metering will not take place at full aperture as it does with an FD lens but, rather, at the same aperture at which the shot will be taken. For stopped-down metering, the aperture ring or A-M ring of an FL lens must be set to "Manual".

The shooting procedure is as follows:

- 1 Focus at the lens' maximum aperture.
- 2 Set the camera for stopped-down metering by setting the multi-purpose lever lock to "L" and pushing the multi-purpose lever towards the lens mount. The multi-purpose lever will lock in that position.
- 3 Turn the meter switch "ON". Only the meter needle will appear in the viewfinder. The circular aperture lever will have disappeared from the field of view.
- 4 To set the exposure, rotate the shutter speed dial or aperture ring, as desired, until the meter needle coincides with the meter index.
- 5 Press the shutter button for exposure.

Stopped-down metering is also necessary whenever an accessory is inserted between the camera and any lens for increasing the lens' focal length or for increasing lens extension for close-up shooting. The only exceptions to this rule are the Extension Tubes FD-U and Extender FD 2X-A which allow normal full-aperture metering with an FD lens. If the accessory used is manual, it will be necessary to set an FD lens for manual diaphragm control before stopped-down metering is possible (see pp. 27-29).

An FD lens is designed for full-aperture metering when it is mounted directly to the F-1 with no accessory between. If you wish to do stopped-down metering when the lens is mounted directly to the camera, the lens must be stopped down to at least f/2.8 or there will be a possibility of exposure error.

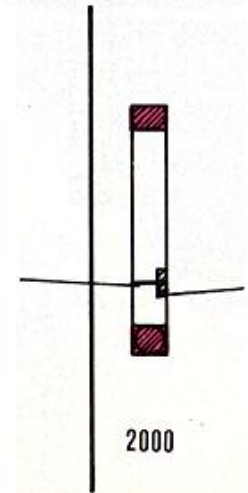
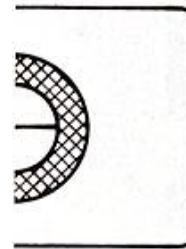

To reset the camera for full-aperture metering with an FD lens, push the multi-purpose lever lock to the white dot. The multi-purpose lever will spring back automatically to its upright position.

How to "Average" Exposures

When measuring a subject influenced by greatly different light intensities, take two measurements, one each of the darkest and lightest parts, and obtain the average value for the two readings. Then, set the f/stop or shutter speed at this average value.

| Film Speed | Shutter Speed | | | | | | | | | | | | |
|----------------|-----------------|-----------------|-----------------|------------------|------------------|------------------|------------------|------------------|------------------|------------------|------------------|------------------|-------|
| ASA 25 | 1 | $\frac{1}{2}$ | $\frac{1}{4}$ | $\frac{1}{8}$ | $\frac{1}{15}$ | $\frac{1}{30}$ | $\frac{1}{60}$ | $\frac{1}{125}$ | $\frac{1}{250}$ | $\frac{1}{500}$ | $\frac{1}{1000}$ | $\frac{1}{2000}$ | |
| ASA 50 | $\frac{1}{2}$ | $\frac{1}{4}$ | $\frac{1}{8}$ | $\frac{1}{15}$ | $\frac{1}{30}$ | $\frac{1}{60}$ | $\frac{1}{125}$ | $\frac{1}{250}$ | $\frac{1}{500}$ | $\frac{1}{1000}$ | $\frac{1}{2000}$ | ... | |
| ASA 100 | $\frac{1}{4}$ | $\frac{1}{8}$ | $\frac{1}{15}$ | $\frac{1}{30}$ | $\frac{1}{60}$ | $\frac{1}{125}$ | $\frac{1}{250}$ | $\frac{1}{500}$ | $\frac{1}{1000}$ | $\frac{1}{2000}$ | ... | ... | |
| ASA 200 | $\frac{1}{8}$ | $\frac{1}{15}$ | $\frac{1}{30}$ | $\frac{1}{60}$ | $\frac{1}{125}$ | $\frac{1}{250}$ | $\frac{1}{500}$ | $\frac{1}{1000}$ | $\frac{1}{2000}$ | ... | ... | ... | |
| ASA 400 | $\frac{1}{15}$ | $\frac{1}{30}$ | $\frac{1}{60}$ | $\frac{1}{125}$ | $\frac{1}{250}$ | $\frac{1}{500}$ | $\frac{1}{1000}$ | $\frac{1}{2000}$ | ... | ... | ... | ... | |
| ASA 800 | $\frac{1}{30}$ | $\frac{1}{60}$ | $\frac{1}{125}$ | $\frac{1}{250}$ | $\frac{1}{500}$ | $\frac{1}{1000}$ | $\frac{1}{2000}$ | ... | ... | ... | ... | ... | |
| ASA 1600 | $\frac{1}{60}$ | $\frac{1}{125}$ | $\frac{1}{250}$ | $\frac{1}{500}$ | $\frac{1}{1000}$ | $\frac{1}{2000}$ | ... | ... | ... | ... | ... | ... | |
| ASA 3200 | $\frac{1}{125}$ | $\frac{1}{250}$ | $\frac{1}{500}$ | $\frac{1}{1000}$ | $\frac{1}{2000}$ | ... | ... | ... | ... | ... | ... | ... | |
| Minimum f/stop | f/22 | f/22 | f/22 | f/22 | f/22 | f/22 | f/22 | f/22 | f/22 | f/16 | f/11 | f/8 | f/5.6 |

Coupling Range of Built-in Exposure Meter

At given film speeds, the built-in exposure meter couples within the f/stops and shutter speeds as indicated in the chart at the left. For example, when using the Canon FD 50mm f/1.4 lens at ASA 100, the exposure meter couples fully within the range of EV 3, f/1.4 at 1/4 of a sec. (the first number as read off the row labelled "ASA 100") to EV 18, f/11 (read off the bottom row) at 1/2000 of a sec. (again read off the "ASA 100" row, but this time read the last number). Thusly the first number of a row indicates the longest shutter speed possible at a given film speed with the aperture fully open while the last number denotes the fastest shutter speed possible with the f/stop used being read from the bottom row as the number directly under the fastest shutter speed.

Holding the Camera

Hold the camera firmly to take a clear picture. Hold the camera either in a vertical or horizontal position, look through the viewfinder, and focus. Then press the shutter release button gently. The following techniques are important to remember:

- 1** Hold the camera snugly in both hands. The camera should be pressed firmly to your cheek or forehead.
- 2** When the camera is in a horizontal position, both elbows should be firmly pressed against the body. At least one elbow should be resting against the body when the camera is in a vertical position.
- 3** Hold your breath and press the shutter release button with a smooth, steady stroke. Otherwise, you will have a blurred picture.
- 4** It is best to use a tripod and cable release when using slow shutter speeds.
- 5** When taking pictures against the light, always use a lens hood.

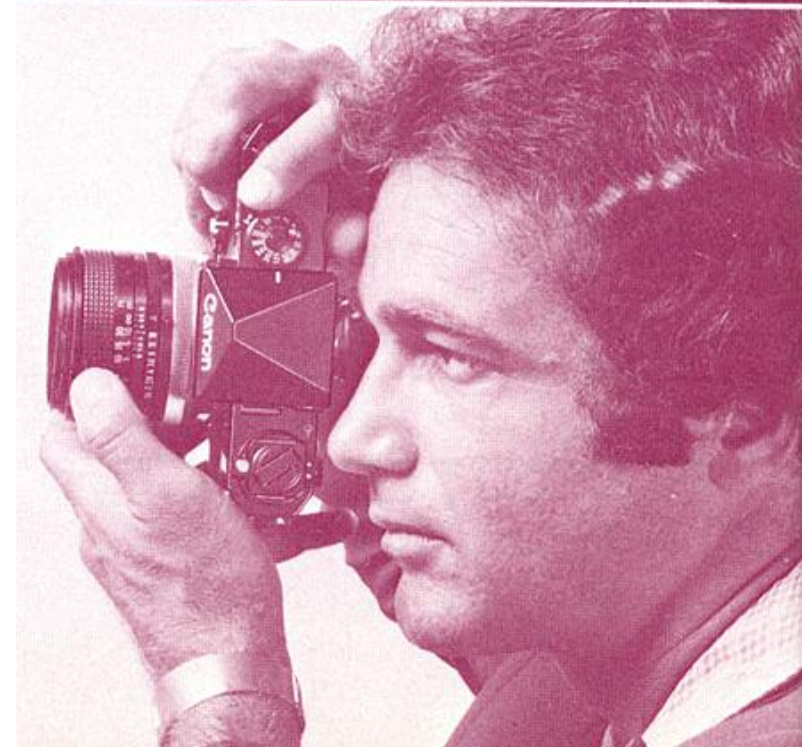
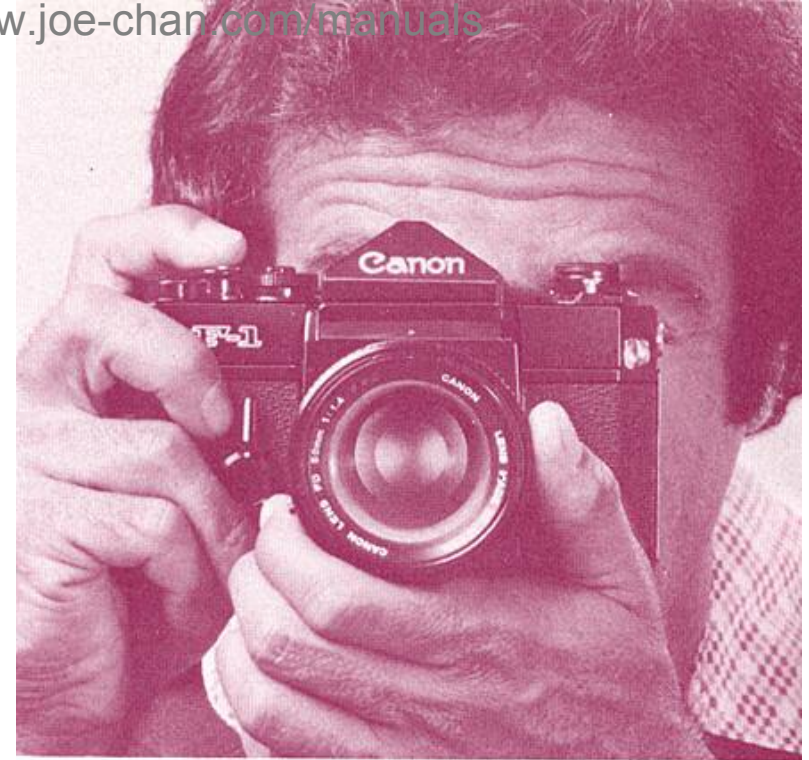

Viewing and Focusing

Focusing is performed in the small round area in the center of the viewfinder. The smaller central circle is a split-image focusing screen and around it is the microprism ring. The split-image rangefinder ascertains that the image is "in focus" when the image divided horizontally in half matches and becomes one complete image.

The microprism rangefinder presents a clear and steady image when in focus. The microprism conveys a broken, shimmering image when not accurately in focus. It is also possible to focus with the matte screen outside the smaller central area. You can focus with either of these focusing aids as you like, depending on the subject condition and your preference.

- A curved line may sometimes be visible in the lower part of the viewfinder according to the angle of the incoming light. This is a reflection of the beam-splitting mirror of the condenser lens in the TTL light measurement system.

Viewfinders

The Eye-level Finder can be removed and interchanged with other viewfinders. To remove the finder, pull it towards the backside of the camera while pressing the two stopper buttons on both sides of the finder. To attach a finder, slide it in from the rear of the camera so that the attachment rails of the viewfinder are level with the camera body. Push it all the way in. It will

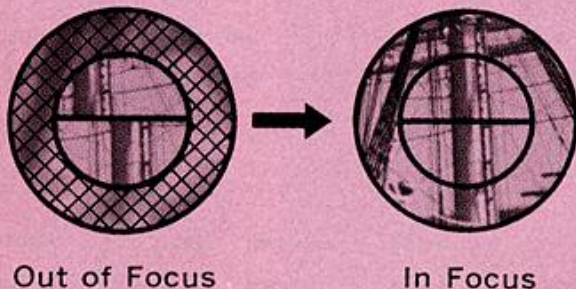
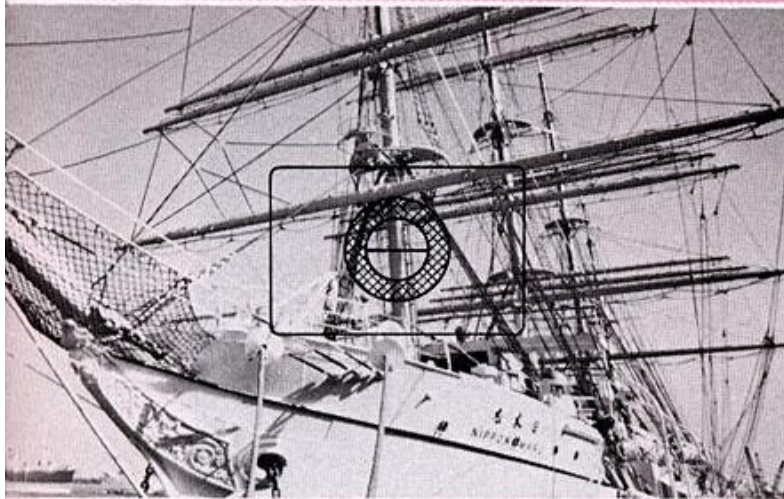
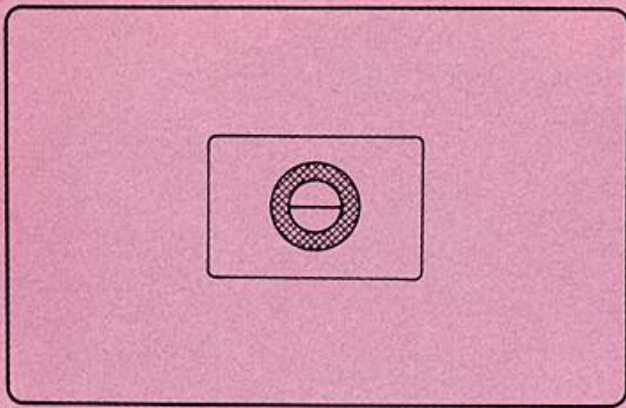

lock in place with an audible click.

Interchangeable viewfinders that can be used include: the Booster T Finder, Servo EE Finder, Speed Finder and Waist-level Finder. (See page 56.)

Focusing Screens

The focusing screen inside the finder box can also be interchanged. The standard focusing screen has a split-image/microprism screen rangefinder. There are eight other types of screens available. They are the microprism rangefinder, split-image, all-matte, matte/section, microprism/large aperture lenses, microprism/small aperture lenses, matte/scale and double cross-hair reticule types. (See page 57.)

To insert a focusing screen, face the protruding part of the screen toward the front of the camera and insert it under the metallic lip on the camera body side. Then, press down on the rear end of the focusing screen so that it drops into a horizontal position.

To avoid marring the one that is removed, lay it upside down with the Fresnel side (the underside when in the camera) up.

Finder Illuminator F

The Finder Illuminator F fits onto the accessory shoe bracket of the F-1 and the built-in lamp lights up exposure meter information. This accessory is used when the lighting condition is poor and not enough light enters the light-taking window for reading the exposure meter information.

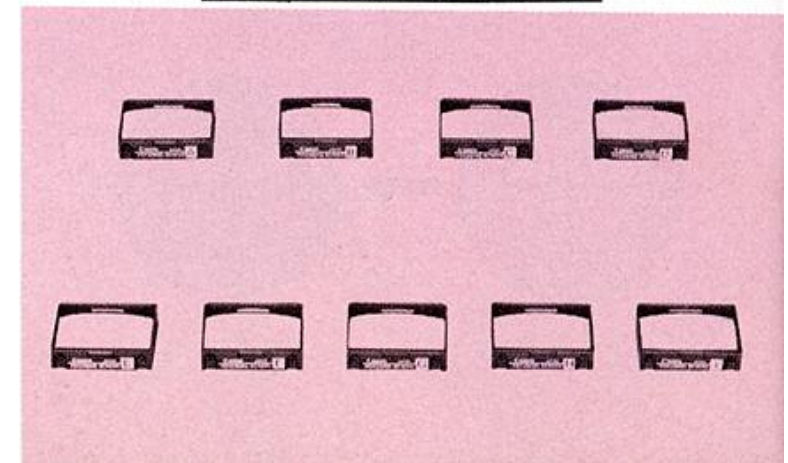
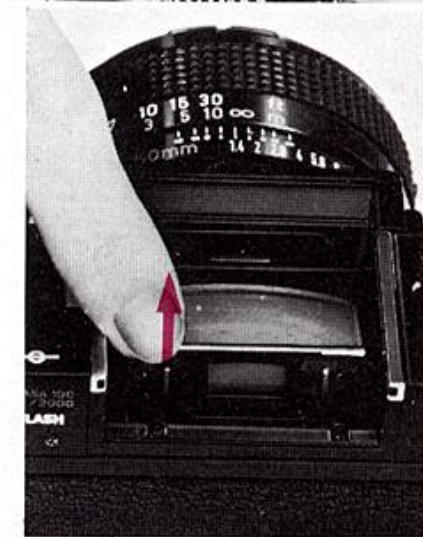

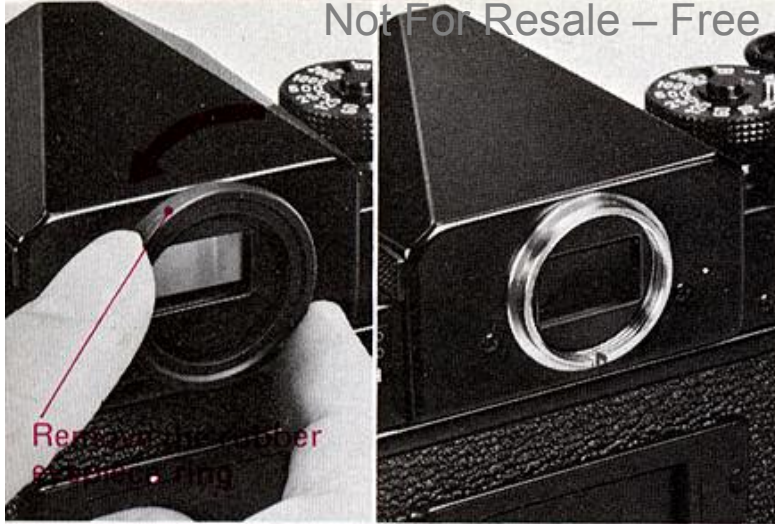

Dioptric Adjustment Lenses

The Rubber Eyepiece Ring — the glassless ring covered with rubber — is attached to the viewfinder. Camera's standard diopter is -1.2 , while ten other kind of screw-in type dioptric adjustment lenses are interchangeable. The diopters of these lenses are adjusted solely for use with the F-1. Thus, the diopters of the lenses are not "true" to their markings when the lenses are used by themselves, but are "true" to their marking when the lenses are taken in conjunction with the camera.

- Dioptric adjustment lenses can also be used when a Magnifier R is attached to the viewfinder eyepiece.
- Dioptric adjustment lenses should be removed when the Angle Finders A2 and B are attached, which are adjustable.

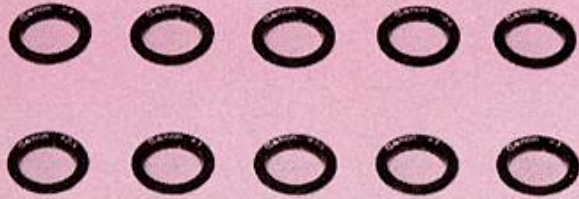

Dioptric Adjustment Lenses:

R-4, R-3, R-2, R-0.5, R0,
R+0.5, R+1, R+1.5, R+2, R+3

Angle Finder A2 and B

The Angle Finders A2 and B can be attached to the eyepiece for copying, photomacrography, and photomicrography.

Magnifier R

The Magnifier R can be attached to the eyepiece which magnifies the rangefinder section for accurate focusing. Because it can be flipped up and locked, the entire field-of-view can be easily viewed after focusing.



Film Rewinding

When the film reaches the end and the film advance lever stops, rewind the film into the cartridge as soon as possible. If you force the film advance lever after the film reaches its end, the film may become detached from the cartridge spool or tear, making rewinding impossible. Be sure not to open the back cover before rewinding. Otherwise, the entire roll will be exposed and ruined as the exposed film is uncovered within the camera.

1 Press the film rewind button found on the bottom of the camera. Once the film rewind button has been pressed, your finger may be removed from it.

2 Raise the film rewind crank, turn it clockwise as indicated in the photo at right by the arrow and rewind the film into the cartridge. When the film rewind button stops revolving and rewinding resistance becomes light, stop rewinding. The finish of the film rewinding will be noticed by the cessation of rewinding noise.

3 Open the back cover.

4 Pull up the rewind knob fully and remove the cartridge.

- The film rewind button will pop out automatically when the back cover is opened.

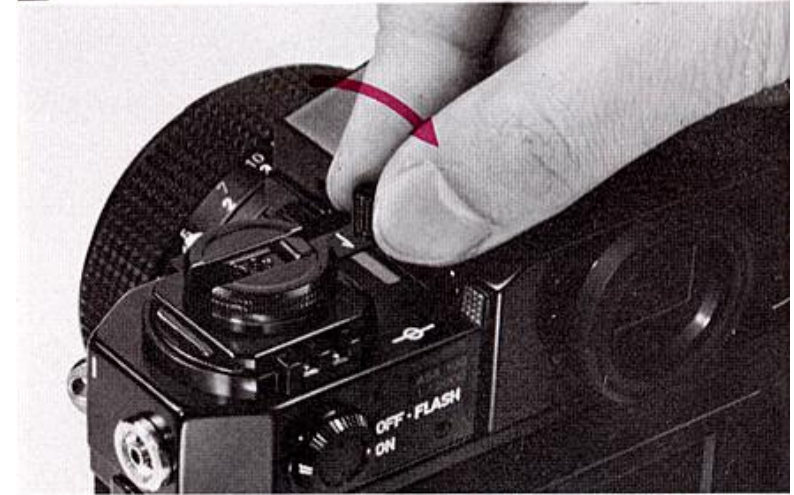



Lens Signal Coupling

Aperture Signal Lever:

The Aperture Signal Lever transmits the f/stop of the automatic aperture to the camera body. It is on a one-to-one movement basis with the aperture through lever manipulation. When the aperture ring is set at the "A" mark for AE photography, the aperture signal lever is disconnected from the aperture ring. The aperture opening can then be set automatically by the Servo EE Finder. The aperture signal lever has a safety device so that the lever is set to the starting position when the Breech-lock mount ring is turned to the attached position.

Full Aperture Signal Pin

The Full Aperture Signal Pin relays the lens's maximum aperture to the meter. This compensates for the meter deviation of the open aperture metering.

Automatic/Manual Aperture Lever

The Automatic/Manual Aperture Lever functions to stop-down the aperture to the preset position. This is the lever that must be locked for manual diaphragm control with a non-coupled accessory.

EE Lock Pin

The EE Lock Pin is a protective pin used to prevent the aperture of the lens from moving to the "A" mark accidentally. To set the aperture of the lens at the "A" mark, turn the aperture ring while pushing down the EE lock pin. To disengage from the "A" mark, turn the





Distance Scale

Index

Infrared Index

aperture ring, again pushing down the EE Lock Pin.

EE Switch Pin

This pin comes out when the lens aperture ring is set at the "A" mark. In this position, it transmits a signal for AE photography.

Distance Scale

The distance scale indicates the distance between the focused subject and the film plane. The scale is necessary for checking the depth-of-field, for flash and for infrared photography. The exact reading from the distance scale is at the center of each number.

Infrared Mark "."

The infrared mark "." is used to make the necessary adjustments to the camera for infrared photography. The correction of the distance scale is required in infrared photography because the focal point deviates slightly from the one in ordinary photography. Focus first in the ordinary manner, then adjust the distance scale to the "." mark imprinted in red. For instance, if the distance scale reads 10m after focusing, merely shift the 10m mark to the "." mark. The position of the "." mark on the F-1 is based on using film with a maximum sensitivity of 800nm such as a Kodak IR 135 film and a Wratten 87 filter.

Film Plane Indicator

The film plane indicator is used in the case when focusing is done by actual measurement. Measure the distance from the film plane indicator and set the measured distance on the distance scale.



Film Plane Indicator

Depth-of-Field Scale

The depth-of-field scale indicates the distances from the camera in which the photograph's subjects will be in sharp focus on the film. For example, if the lens used is a 50mm lens and the subject has been focused at a distance of 3m (10'), with an f/8 value, read off from the scale on either side of the indicator (orange line). The depth-of-field is from approximately 2.3m (8') to 4.3m (14'). If the aperture is closed down to f/16, the picture will become sharp between 1.9m (6') to 7.6m (25') from the camera. Basically, the smaller the f/stop, the greater the distance of the subject from the camera; or, the shorter the lens focal length, the deeper will be the depth-of-field. On the other hand, the larger the f/stop, the nearer the subject to the camera; or, the longer the lens focal length, the shallower will be the depth-of-field.

In the case of Canon FD lenses, you can see the actual sharpness through the viewfinder by pressing the stopped-down lever.

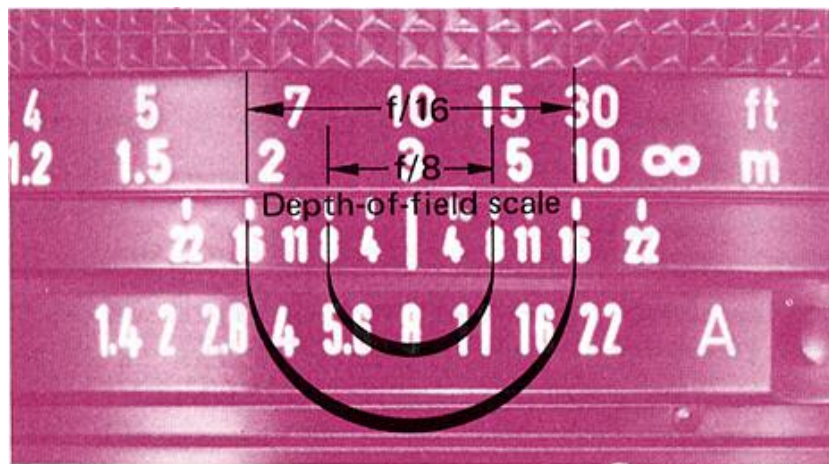

50mm Lens f/8

Depth-of-field 2.3-4.3m (8'-14')
Focused at 3m (10')



50mm Lens f/16

Depth-of-field 1.9-7.6m (6'-25')
Focused at 3m (10')



FD Lens Mount (FL and R Series Lenses)

All Canon FD and FL lenses can be used with the Canon F-1, except the FLP 38mm f/2.8.

It is also possible to attach and use all the R lenses for the Canonflex. However, as the preset aperture mechanism differs, it is necessary to use manual diaphragm control.



Lens Hood

When shooting into bright light, light rays entering the lens may form defects on the image called ghost and flare. Attaching a hood onto the lens helps to prevent this. Bayonet-mount hoods are available as optional accessories for most Canon lenses. Please use only that hood which is specified for the lens concerned. This type of hood fits into the bayonet mount at the front of the lens where it is fixed by turning until it is tight. Some hoods for wide-angle lenses require proper positioning before mounting. Align the red dot on this type of hood with the notch in the bayonet mount at the front of the lens. Then lightly push the hood into the mount and turn it until it is tight.

When not in use, the hood can be mounted in reverse on a standard or some wide-angle lenses, in which case even the hood will fit perfectly into the camera's case.



Flash Photography

Since the F-1 has an interchangeable viewfinder, it is not equipped with a built-in hot shoe. Canon offers two accessory hot shoes which slide into the guide rails at the base of the F-1's rewind knob from the back of the camera. Flash Coupler D is a simple hot shoe for direct contact flashes. Flash Coupler L is a hot shoe which also has special contacts for semi-automatic flash with the Canon Speedlite 133D using the Canon Auto Tuning (CAT) System. This coupler is also equipped with a lamp for illuminating viewfinder information. The synchronization cord of a flash which lacks a direct contact must be branched to the F-1's PC socket.

Flash photography is possible with the CAT System using the Canon Speedlite 133D, the Canon FD 50mm f/1.4 S.S.C., FD 50mm f/1.8 S.C., FD 35mm f/2 S.S.C. or FD 35mm f/3.5 S.C. lens and either Flash Auto Ring A2 or B2, depending on the lens. After Flash Coupler L is locked into position by pushing its lock lever upwards, the Speedlite 133D may be slipped into its hot shoe from the rear. The appropriate Flash Auto Ring should then be mounted on the front of one of the four above lenses and its cord connected to the flash. The Flash Auto Ring relays the shooting distance to the camera meter. Proper exposure is obtained by matching needles as usual after the shutter speed has been set to the synchronization speed of 1/60 sec. and the Speedlite's main switch to AUTO.

Canon Speedlite 133D

Flash Coupler L



Flash Auto Ring



Sync.
Contact for
Flash Unit

Contact for
CAT System

Manual flash is also possible with the Speedlite 133D on MANUAL. In this case, it is necessary to figure the correct aperture by guide number formula:

$$\text{Aperture} = \frac{\text{Guide Number}}{\text{Shooting Distance}}$$

Make sure both guide number and shooting distance are in the same unit, whether meters or feet. For further details on the use of the Canon Speedlite 133D, please see its instructions.

The following table gives proper synchronization shutter speeds for flash photography with various other types of flash units and bulbs. When using a flash other than Speedlite 133D, it is necessary to figure the correct aperture by guide number calculation as described above or, in the case of an automatic electronic unit, by its calculator dial. Follow the instructions of the particular flash.

| Type | | Synchronised Shutter Speeds |
|-----------------------|--|-----------------------------------|
| Flash-bulbs | FP class (#6, Press 26) | 1/125 or faster 1/30 or slower |
| | M class (M3, #5, Press 25) | 1/30 or slower |
| | MF class AG-1, AG-3 (M2, Flashcube) | 1/30 or slower |
| Electronic Flash Unit | | 1/60 or slower |

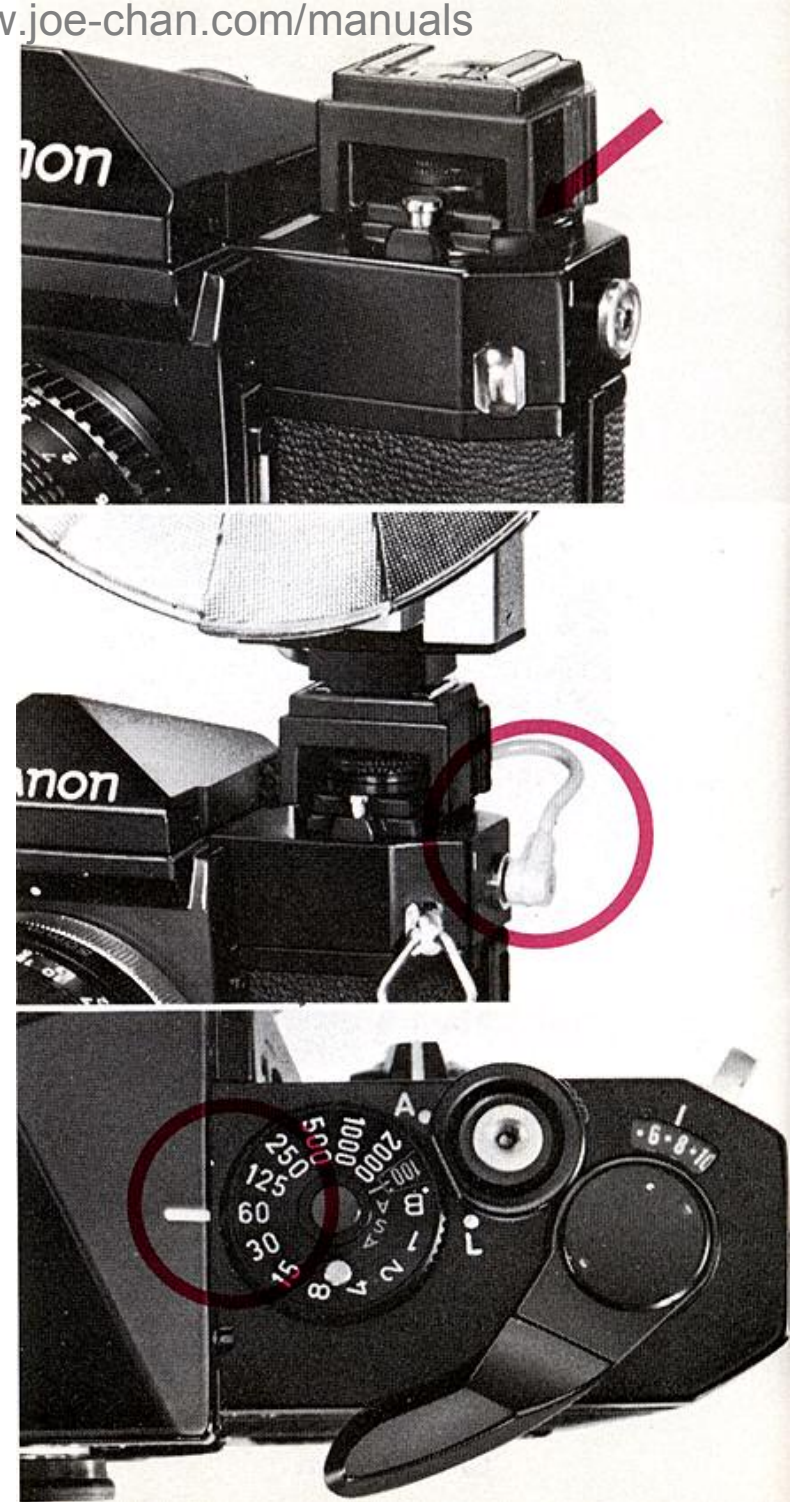

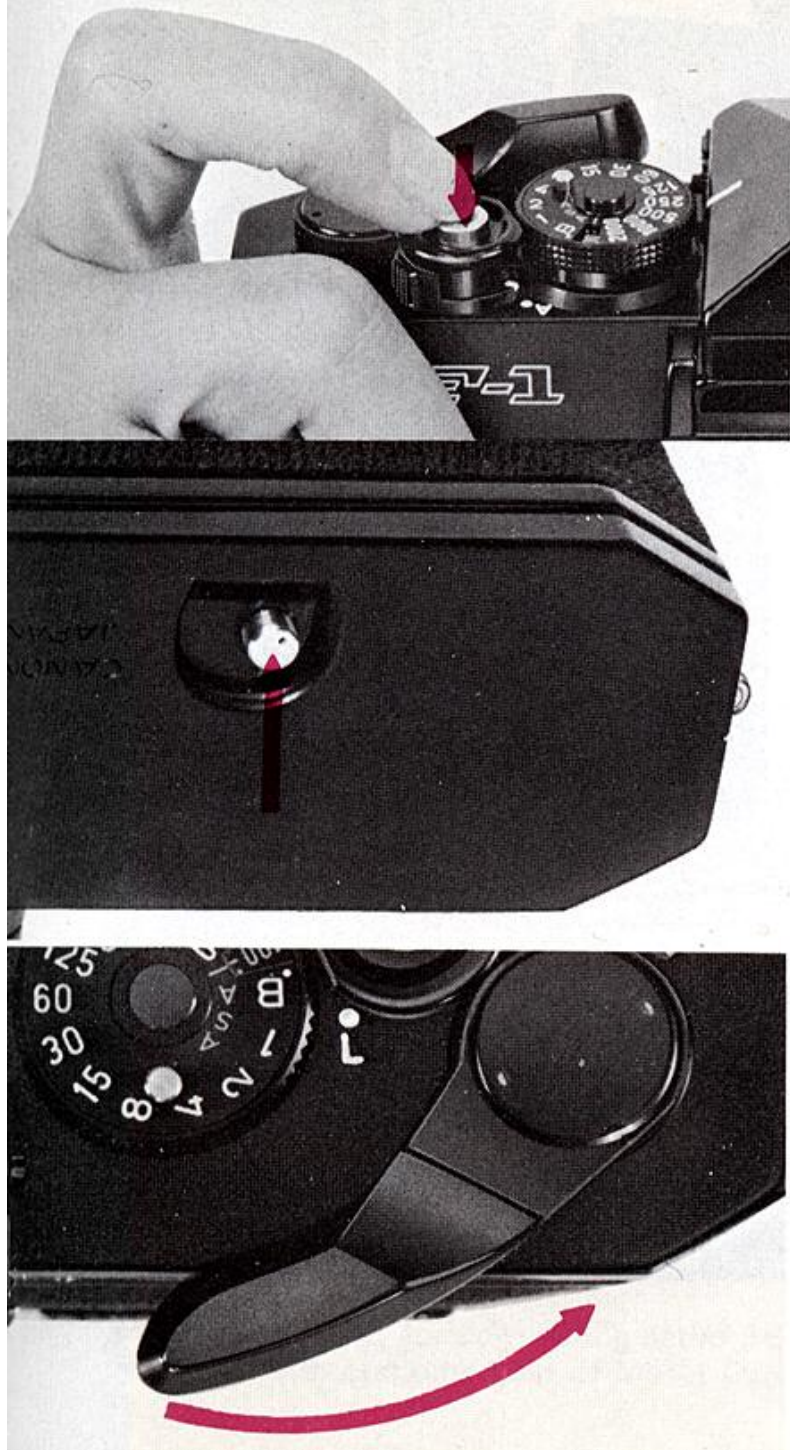

Multiple Exposures

When more than one exposure of the same subject or different subjects are printed in the same frame, it is called multiple exposure photography. In answer to the demands for this type of mechanism, Canon designed the F-1 with this option.

- 1 Turn the film rewind crank gently to take up the film's slack.
- 2 Compose the picture and press the shutter button.
- 3 Depress the film rewind button on the bottom of the camera. Even if you remove your finger from the button, it will remain depressed.
- 4 Turn the film advance lever gently with single winding. Do not turn it with short-stroke winding.

If you repeatedly follow the above procedure, you can take as many pictures as you'd like with the same frame of film. In some cases, the picture frames may be slightly shifted. The exposure value of the multiple exposure can not be simply decided by the number of exposures and the brightness of subjects. There are two methods of adjustment, one by using the ASA adjustment ring, the other by adjusting the aperture manually, and both need photographer's experience. It is best to start photography with the darker subjects, and end with the lighter subject.

- When you have taken pictures of multiple exposures, the frame counter will advance by one each time you turn the film advance lever.
- Do not take multiple exposure photographs when attaching a Motor Drive.

Using the Self-Timer

- 1 Wind the film advance lever.
- 2 Turn the multi-purpose lever counter-clockwise until it stops.
- 3 Depress the shutter release button. The shutter will be released approximately 10 seconds later.
 - Be sure to wind the film advance lever. Otherwise the self-timer will act but the shutter will not be released.
 - The multi-purpose lever can also be used as the stop-down lever even after the self-timer is cocked.
 - If the self-timer lever is set while the mirror is in an up-position, the mirror is released. Therefore, always reset the mirror in the up-position after setting the self-timer.
 - If the self-timer lever is turned halfway, the shutter button is locked and doesn't work. It doesn't get out of order, because the shutter button will be released after continuing to turn the lever completely.





Removing the Bottom and Back Covers

The bottom cover can be removed for use of the Motor Drive MF. When removing the bottom, take off the battery compartment cover and lift the bottom off. The back cover can be removed for attaching the Film Chamber 250 or the Data Back F. When removing the back cover, push down the pin of the hinge.

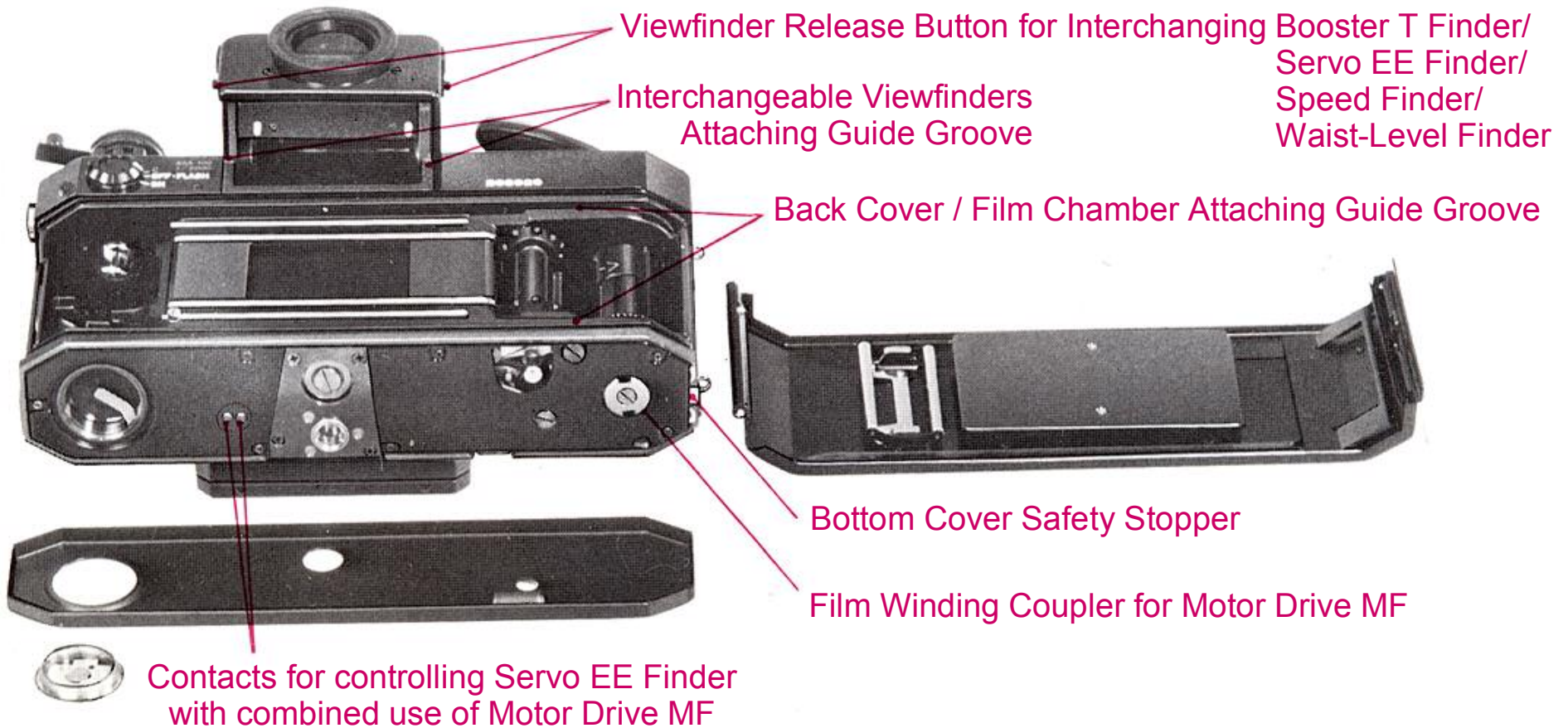

Fixing the Mirror Upwards

In performing super-telephoto or photomicrography, the Canon F-1 can be operated with the mirror locked in the up-position after the picture has been composed in the viewfinder. To lock the mirror in the up-position, push the stopped-down lever-towards the lens and the lock lever to "M". The aperture is now stopped-down and controlled manually.

- The mirror can be locked independently from film advance and shutter speed operations.
- When the mirror is locked in the up-position, SLR viewing is not possible, distance must be estimated by eye, and the 1/2000 second shutter speed cannot be used.
- When the mirror is locked, keep the lens covered if you are not using the camera. The film will sometimes be fogged if the lens cap is left unattached.
- After the mirror lock device has been used, be sure to return the mirror lock lever to its original position. Failure to do this will result in inexact focusing.
- When the original model Canon FL 19mm f/3.5 lens is used, the mirror should be fixed in the up-position. Use of the special viewfinder made for this lens becomes necessary.



Canon F-1 ACCESSORIES



Motor Drive System and Power System

1. Motor Drive MF

The Motor Drive MF enables you to take 3.5 pictures per second and is totally compatible with the full line of accessories for the Canon F-1, especially the Film Chamber 250, Servo EE Finder and Interval Timer L.

2. Power Winder F

The Power Winder F is a motorized winder accessory for the F-1. It is compact and lightweight and attaches to the base of the camera. The grip section with two shutter release buttons for convenience and the base/power source section is a one-piece unit. Shooting in continuous mode enables two frames-per-second film advance.

3. Film Chamber 250

The Film Chamber 250 is an exclusive long-length film roll magazine designed to hold at capacity 250 exposures. Made to guarantee single-frame exposures, with the combined use of the Motor Drive MF, it is effective for shooting sports events and copying documents.

4. Connecting Cord for Grip MF

This is an extension cord that connects the Motor Drive MF and the grip. It serves to release the shutter when at a certain distance away from the camera.

5. Connecting Cord MF

This cord connects the Motor Drive MF and the electric circuit of the Servo EE Finder.

6. Remote Switch 60 and Remote Switch 3 (for Power Winder F)

The 60cm-long Remote Switch 60 and the 3m-long Remote Switch 3 can be used for remote control shooting in both continuous mode and single-frames.

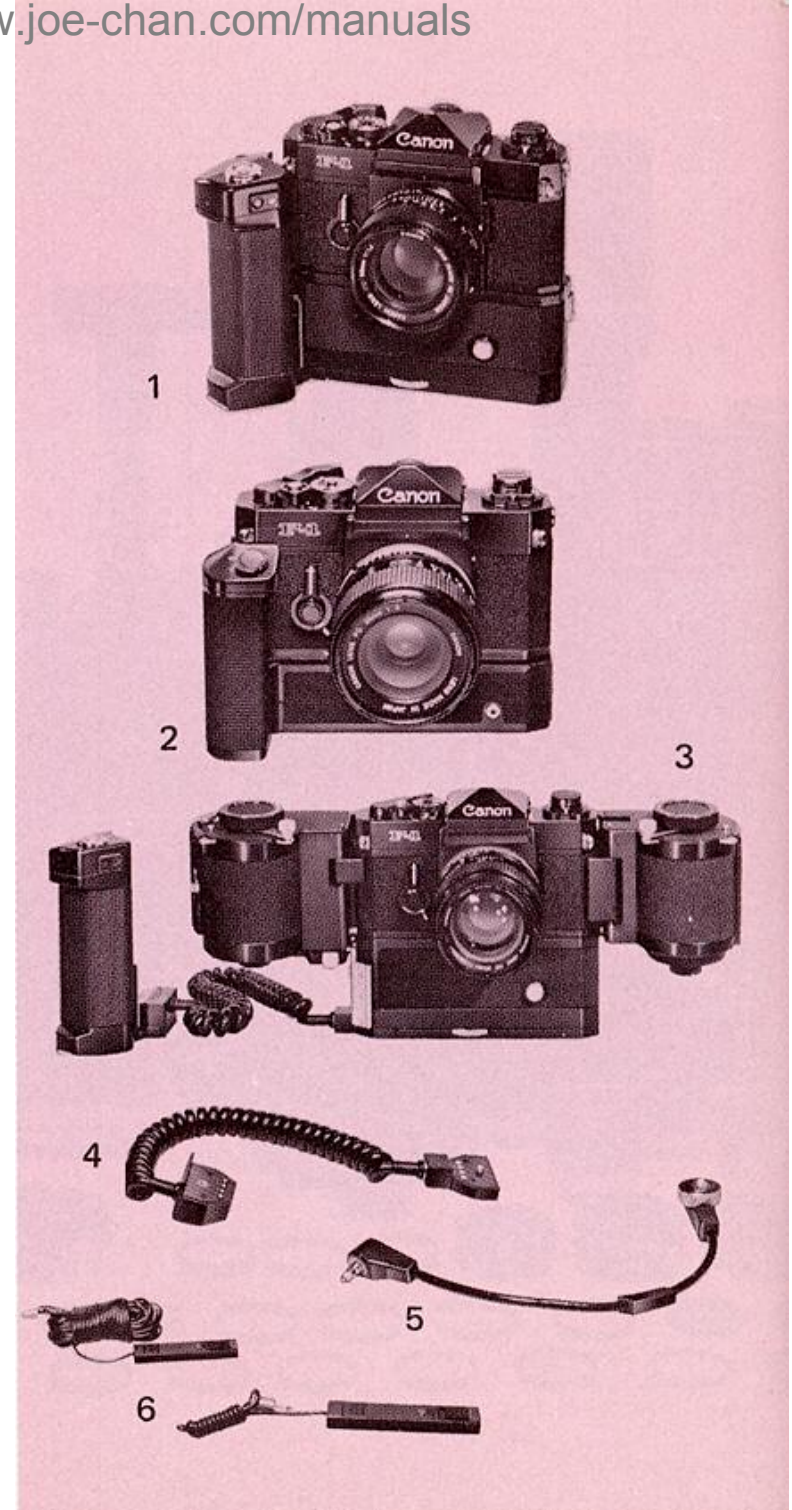

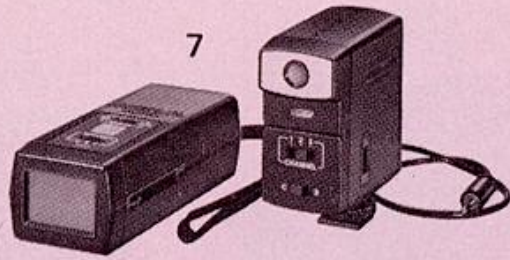

7

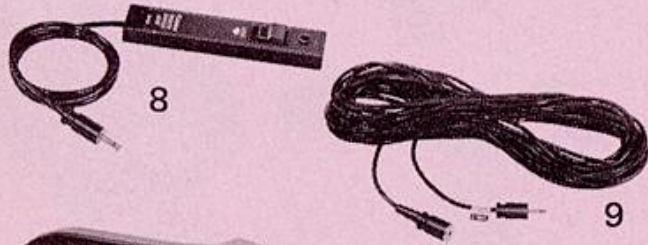

8

9

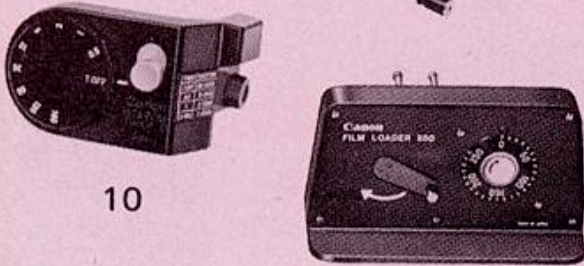

10

11



12

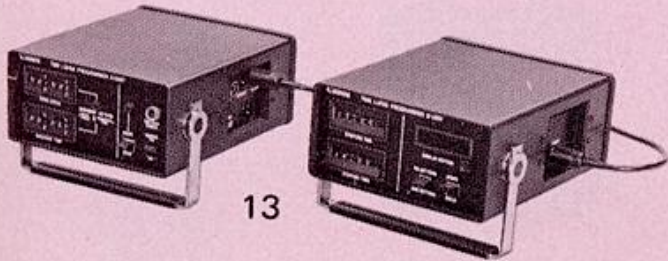

13

7. **Wireless Controller LC-1 Set**

This is a remote control device to control cameras from distance without cord connections. The LC-1 set consists of a transmitter and a receiver and the receiver is attached to the F-1 which is to be equipped with the Motor Drive MF or Power Winder F.

8. **Remote Switch 60 MF (for Motor Drive MF)**

This equipment with 60cm-long cord is inserted in the remote control jack and used when at a distance away from the camera.

9. **Extension Cord E1000**

This 10m-long cord is used by inserting one end of it to the remote control jack and the other end to the Remote Control Switch 60 MF, Remote Switch 60, or Remote Switch 3. It is also possible to connect it to the Interval Timer L.

10. **Interval Timer L (for Motor Drive MF)**

This timer is used directly in connecting it to the remote control jack. The shooting time is controlled at 3.5 frames per second and at nine other speeds between one frame every 0.5 second and 180 seconds.

11. **Film Loader 250**

The Film Loader 250 is a film winding device used to load bulk film into the Film Magazine 250 for the Film Chamber 250.

12. **Film Magazine 250**

The Film Magazine 250 is for the Film Chamber 250. It can hold a maximum of 250 exposures.

13. **Time Lapse Programmer**

The Time Lapse Programmer, composed of the A Unit and B Unit, is an electrical photography system employing the F-1 equipped with the Motor Drive MF. It affords unmanned photography for interval motion and work sampling shooting. The A Unit functions to control the length of filming for the release of the shutter for the F-1 at specified intervals, while the B Unit controls the time periods the A Unit functions in.

Viewfinder System

1. Servo EE Finder

The Servo EE Finder is an interchangeable viewfinder, which couples to the full aperture metering mechanism of the FD lenses. It presets the proper f/stop automatically with shutter speed priority. The Cord 12V 2E is used for connecting the Servo EE Finder to the Battery Case.

2. Booster T Finder

The Booster T Finder with its built-in timer is used for precise exposure reading down to 60 sec. under extremely dim light conditions. Metering range is from EV 10 (f/22 at 1/2 sec.) to EV -3.5 (f/1.2 at 15 sec.) with ASA 100 film. The Cord 6V 2B is used for connecting the Booster T Finder to the Battery Case.

3. Speed Finder

The Speed Finder is an extremely versatile viewfinder used for all kinds of photography, from over head shots to copy work. This viewfinder can be changed into an Eye-level Finder or Waist-level Finder by simply adjusting the rear section of the optical system. The eye point of the Speed Finder is located 60mm in back of the eyepiece.

4. Waist-level Finder

The Waist-level Finder is an interchangeable viewfinder with built-in 5X magnifier glass. This viewfinder is very effective for low position photography and for focusing in copy work.

5. Finder Illuminator F

The Finder Illuminator F is essentially a small battery-powered lamp which slips over the viewfinder illumination window next to the pentaprism to facilitate reading viewfinder information in poor lighting. It will be most appreciated in any low-light situation in which the Booster T or Servo EE Finder is not used.

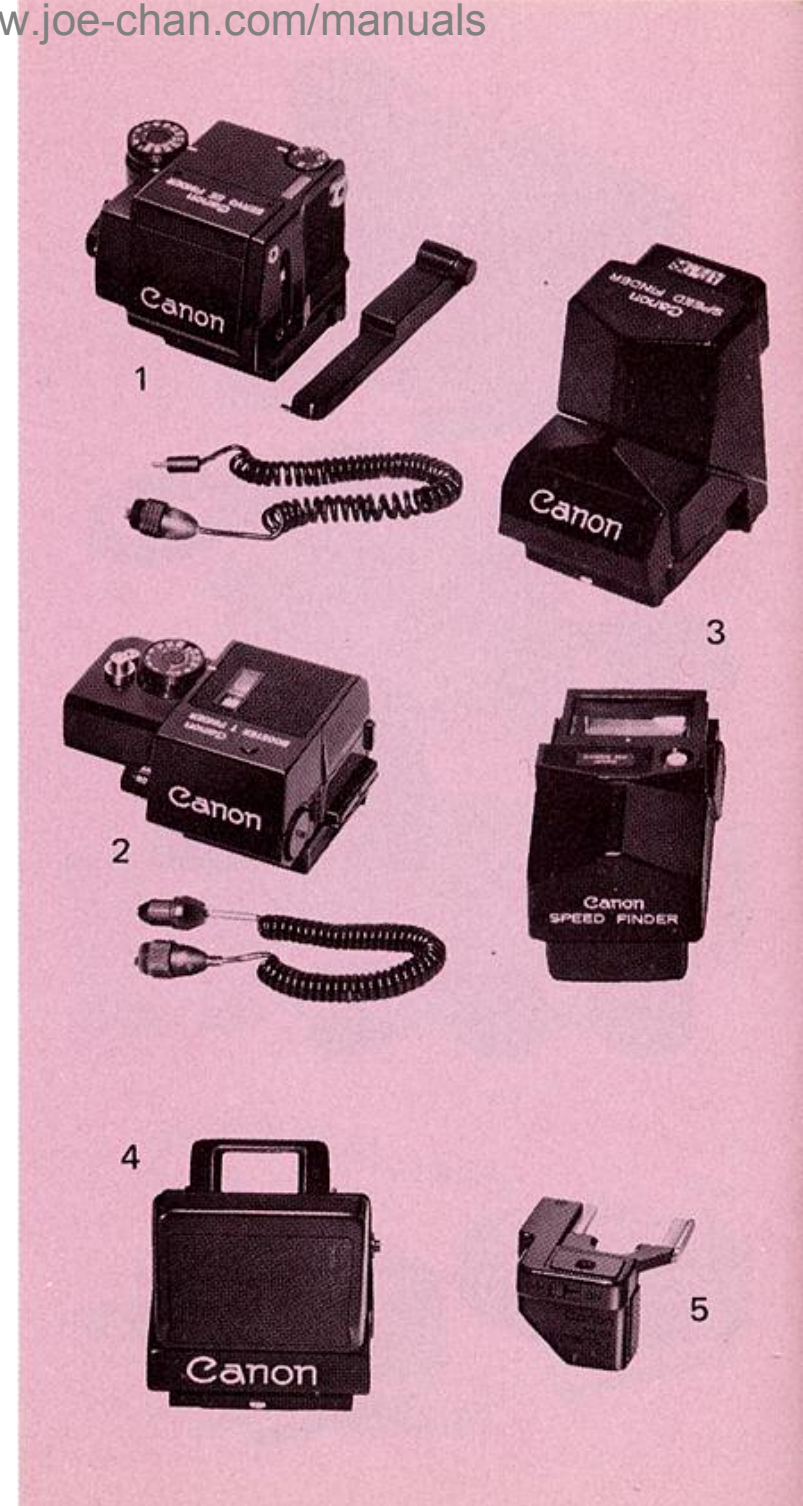

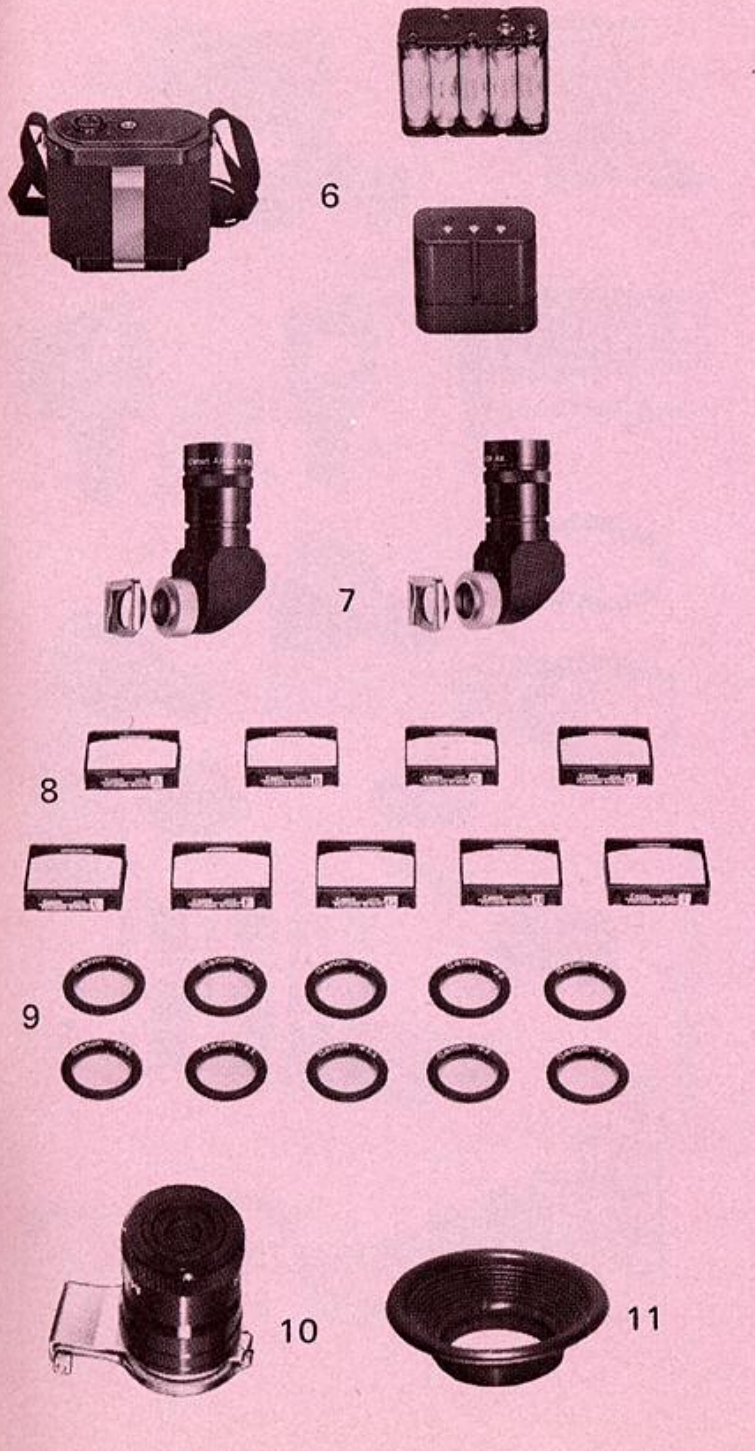

6. Battery Case

The Battery Case holds an external power source and is used for the Servo EE Finder and Booster T Finder. This versatile battery case can use the Battery Magazine 15V containing 10 penlight batteries or Battery Magazine 12V containing 8 penlight batteries.

7. Angle Finders A2, B

The Angle Finder B is a right angle attachment that presents an exact reading of the entire field of view. It is very convenient for copy work, close-up photography and shooting a subject from a low angle. The Angle Finder A2 is a simplified version of the Angle Finder B which shows an erect, but reversed image.

8. Focusing Screens

Nine types of focusing screens are available: Focusing Screen A (microprism type), B (split-image type), C (all-matte type), D (matte/section type) E (split-image/microprism), F (microprism/large aperture lenses), G (microprism/small aperture lens), H (matte/scale) and I (double cross-hair reticule). Usually, the F-1 is sold with Focusing Screen E.

9. Dioptric Adjustment Lenses

Four kinds of interchangeable dioptric adjustment lenses for nearsightedness and six kinds for farsightedness are available: R-0.5, R-2, R-3 and R-4 for nearsightedness; R 0, R+0.5, R+1, R+1.5, R+2 and R+3 for farsightedness. The F-1 comes equipped with the standard lensless R-1 ring.

10. Magnifier R

The Magnifier R is used for magnifying the focusing screen so that an accurate focus can be obtained. It can be attached to the eyepiece of the Eye-level Finder, Booster T Finder or Servo EE Finder.

11. Eyecup R

The Eyecup R is an eyepiece hood for shielding out light. This is attached on the dioptric adjustment ring.

Close-up, Photomacrography and Photomicrography

1. Auto Bellows

The Auto Bellows is a sophisticated bellows for photomacrography, Automatic diaphragm coupling possible with the Auto Bellows when the Double Cable Release is jointly used.

2. Bellows FL

The Bellows FL is used for the extreme close-up photography. It has a shooting distance adjustment mechanism which couples to the automatic diaphragm of the FD and FL lens.

3. Bellows M

The Bellows M is a handy bellows for photomacrography. When the Double Cable Release is used with the Canon Macro Auto Ring, automatic diaphragm coupling is also possible with this bellows unit.

4. Duplicator 35

The Duplicator 35 is used with the Auto Bellows for copying 35mm slides. It can also be used to duplicate and convert a 110-size slides into a 35mm film frame.

5. Slide Duplicator

The Slide Duplicator is used for duplicating color slides or black-and-white slides. It is attached to the tip of the Bellows FL.

6. Duplicators 8, 16

These duplicators are adapters for enlarging and duplicating single frames of 8mm and 16mm movie films to a 35mm format. Macrophoto Lenses are used for duplicating 8mm and 16mm.

7. 52mm, 58mm Close-up Lenses (240, 450)

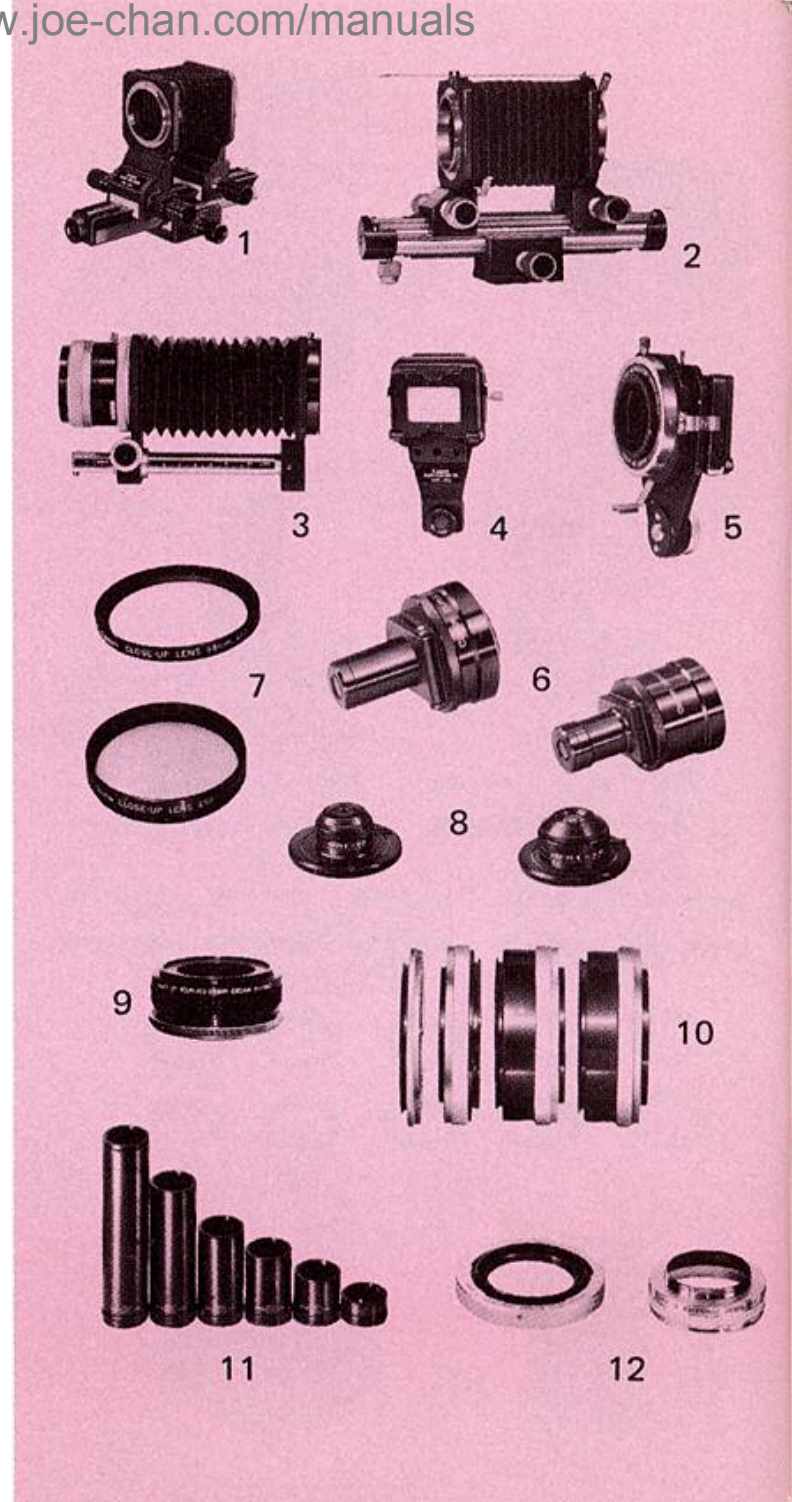

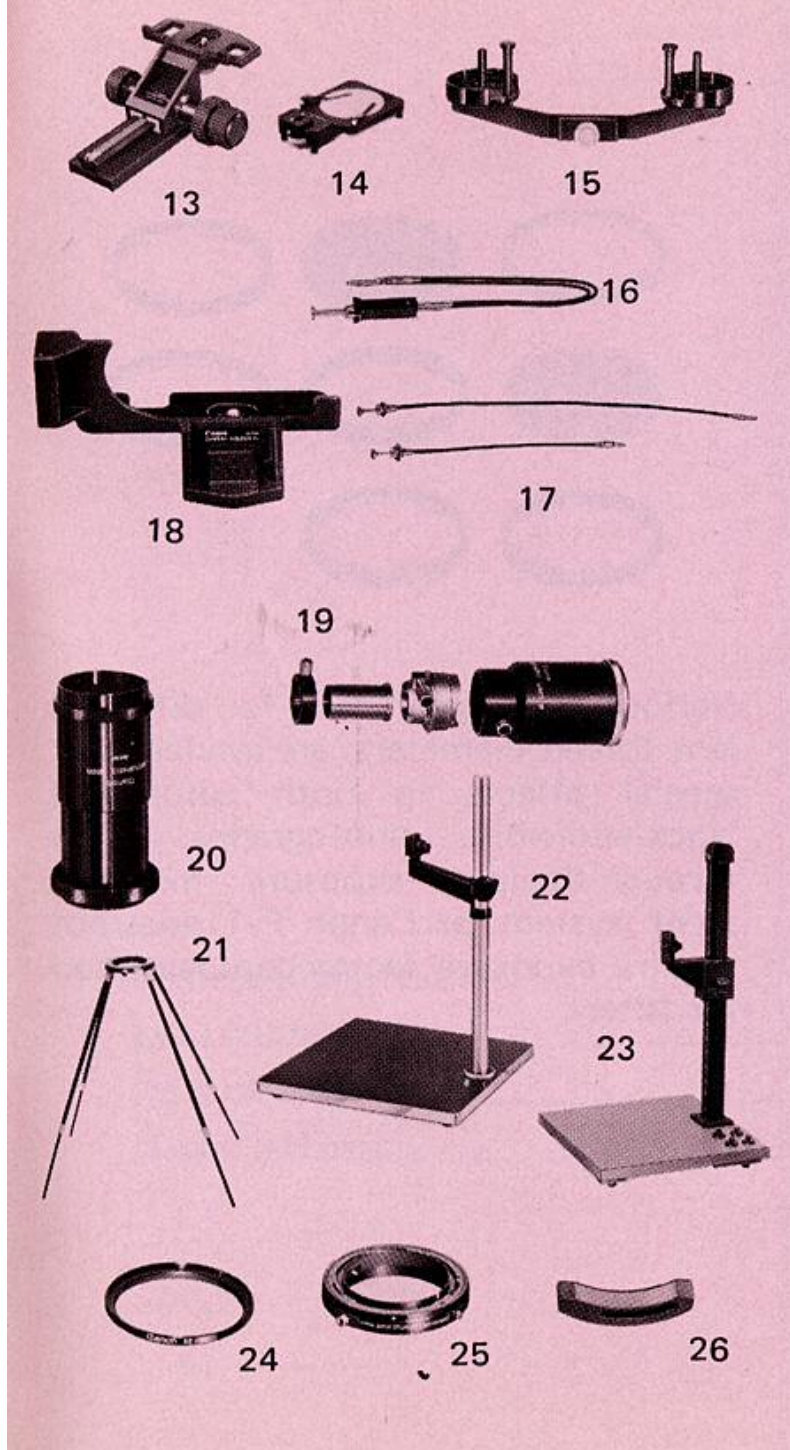

8. Macrophoto Lenses

The Macrophoto Lenses are designed exclusively for high-magnification photomacrography and used jointly with a bellows. Magnification of from 2 to 10 times the actual subject can be obtained in continuous alterations.

9. Macrophoto Couplers FL 52, FL 58

10. Extension Tube M Set

11. Extension Tubes from 6mm to 200mm

12. Lens Mount Converters A, B

13. Focusing Rail

The Focusing Rail is an accessory that is attached to the Copy Stand 4 or 5 for adjusting the position of the camera.

14. Macro Stage

The Macro Stage is a small round plat form which attaches to the end of the Auto Bellows rail to hold the subject in place in high-magnification photography.

15. Roll Film Stage

The Roll Film Stage can be used attached to the front of the Duplicator 35 when duplicating long roll film.

16. Double Cable Release

17. Releases 50, 30

18. Camera Holder F3

The Camera Holder F3 is used in combination with a tripod or a Copy Stand 4 or 5 for photomacrography and copy work.

19. Photomicro Unit F

20. Microphoto Hood

21. Handy Stand F

22. Copy Stand 4

23. Copy Stand 5

24. 52-55 Step-up Ring

25. Macro Auto Ring

26. Manual Diaphragm Adapter

Filters

| Type | Effectiveness of Filters |
|-------------|--|
| ○ ● UV | Absorbs only ultra-violet rays. Especially effective at seaside, and on high mountains. Recommended for use in color photography. |
| ○ Y1 Y3 | Increases contrast of black and white film. Enhances clouds, darkens the blue sky. Brightens red and yellow. |
| ○ O1 | Darkens blue, lightens yellow and red perceptibly. Good for contrasts especially in distant landscapes. |
| ○ R1 | Makes strong contrasts. May also be used with infrared film. |
| ○ G1 | Prevents red from turning radically into white. Lightens sky and face appropriately, and reflects the lightness of fresh greenery. |
| ○ ● ND4 ND8 | ND4 reduces light values by 1/4, ND8 by 1/8. No effect on the reproduction of colors. |
| ● SKYLIGHT | Acts to harmonize the blue sky and shade. |
| ● CCA4 | For use with daylight type film under cloudy conditions. |
| ● CCA8 | For use with tungsten type film in the morning sun or sunset. |
| ● CCA(12) | For use with tungsten type film under sunlight. |
| ● CCB4 | For use with daylight type film in the morning sun or sunset. |
| ● CCB8 | For use with daylight type film and clear flash bulb. |
| ● CCB(12) | For use with daylight type film under tungsten light. |

○ For black and white film. ● For color film.



Various types of filters, for different lens thread diameters, are available for special effects in both color and black-and-white photographs. The through-the-lens exposure measurement system of Canon F-1 does not require exposure factor compensation for filters.

Data Imprinting System

Data Back F

The Data Back F is a data imprinting device designed exclusively for the F-1. There are three separate dials to record the figures for day, month, and year. Certain codes may also be recorded by using certain letters in the alphabet provided and by using Roman numerals from I to X. One or two of the dials or the entire system can be switched off. Automatic imprinting simultaneous to shutter release as well as manual imprinting after the shooting are possible.



Other Accessories

1. **Hard Case S**
Hard Case L
2. **Snap Case SA - 1**
Snap Case SB - 1
Snap Case SC - 1
3. **Gadget Bag 4**
Gadget Bag G - 1
Gadget Bag GM - 1
Gadget Bag GL - 1
Gadget Bag GL - 2
Gadget Bag GS - 1
Gadget Bag L - 1
4. **Holder for Gelatin Filter**
with Filter Holder
Adapter and Hoods
5. **Lens Hood**
6. **Lens Cap**
7. **Lens Dust Cap**
8. **Neck Strap 6 w/pad**



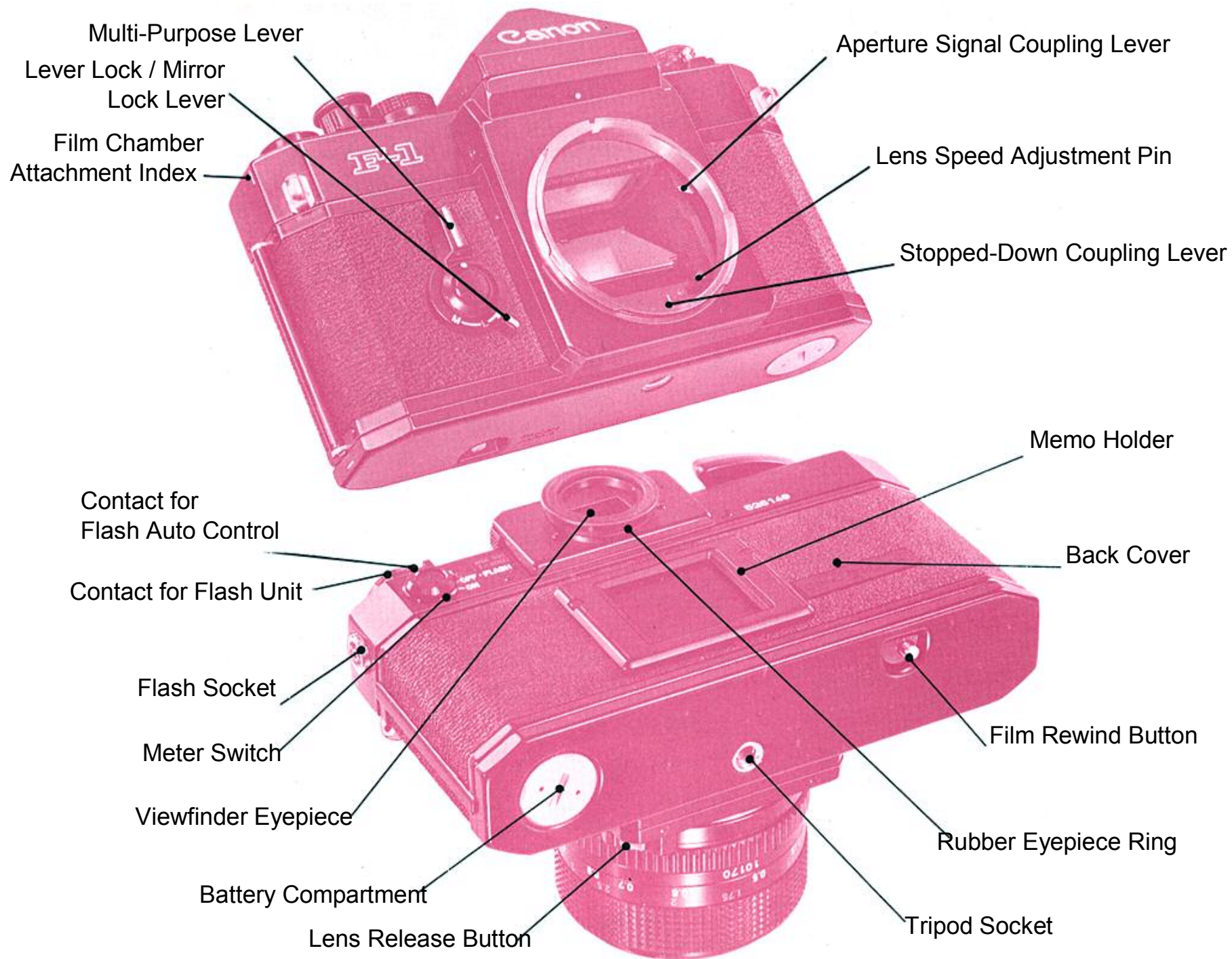

Proper Care of the Camera

Moisture and dust are harmful to your camera. If your camera is to be stored for a long time, it should be removed from its case and silica gel or another drying agent should be placed alongside it. When you use your camera on a rainy day or at the beach, moisture and salt spray adhere to it, which can result in stains, rust and corrosion. Use a soft brush to get rid of dust and a soft dry cloth for wiping.

Some other important tips to remember are:

- In extremely cold areas, expose the camera to the outer air only when in use. When using, expose the camera gradually to the outer air to prevent the lens from clouding.
- Do not keep the camera in a hot place such as a glove compartment or the rear window shelf of an automobile. The heat will harm your camera and film.
- Do not expose the camera to the sun without the lens cap on. It could fog the film or burn a pin-hole in the shutter curtain.
- If the camera will not be used for an extended length of time, the battery should be taken out to prevent possible damage to the terminals from battery corrosion.

Cleaning the Lens

Use a blower or brush lightly with a brush to remove dust on the lens. If you should advertently get a fingerprint on the lens, wipe in a circular motion with lens cleaning material that has been lightly dipped in either pure alcohol or ether and wrapped around a match stick.

Camera Body Number _____
Lens Number _____
Date of Purchase _____
Dealer's Name _____

Canon

CANON INC. 11-28, Mita 3-chome, Minato-ku, Tokyo 108, Japan

U.S.A. ————— **CANON U.S.A., INC. HEAD OFFICE**
10 Nevada Drive, Lake Success, Long Island, N.Y. 11042, U.S.A.
CANON U.S.A., INC. MANHATTAN SERVICE STATION
600 Third Avenue, New York, N.Y. 10016, U.S.A.
CANON U.S.A., INC. ATLANTA OFFICE
6380 Peachtree Industrial Blvd., Norcross, Georgia 30071, U.S.A.
CANON U.S.A., INC. CHICAGO OFFICE
140 Industrial Drive, Elmhurst, Illinois 60126 U.S.A.
CANON U.S.A., INC. LOS ANGELES OFFICE
123 Paularino Avenue East, Costa Mesa, California 92626, U.S.A.
CANON U.S.A., INC. LOS ANGELES SERVICE STATION
3407 West 6th Street, Los Angeles, California 90020, U.S.A.
CANON U.S.A., INC. SAN FRANCISCO SERVICE STATION
776 Market Street, San Francisco, California 94102, U.S.A.
CANON U.S.A., INC. HAWAII OFFICE
Bldg. B-2, 1050 Ala Moana Blvd., Honolulu, Hawaii 96814, U.S.A.

CANADA ————— **CANON OPTICS & BUSINESS MACHINES CANADA, LTD.**
HEAD OFFICE
3245 American Drive, Mississauga, Ontario L4V 1N4, Canada
CANON OPTICS & BUSINESS MACHINES CANADA, LTD.
MONTREAL OFFICE
3070 Brabant-Marineau Street, St. Laurent, Quebec H4S 1K7, Canada
CANON OPTICS & BUSINESS MACHINES CANADA, LTD.
VANCOUVER OFFICE
5900A, No.2 Road, Richmond, B.C. V7C 4R9, Canada
CANON OPTICS & BUSINESS MACHINES CANADA, LTD.
EDMONTON SERVICE CENTER
5222-86 St. Edmonton, Alberta T6E 5J6, Canada

EUROPE AFRICA & MIDDLE EAST ————— **CANON AMSTERDAM NV**
P.O. Box 7907, 1008 AC Amsterdam, The Netherlands
CANON AMSTERDAM NV CAMERA SERVICE CENTER
Gebouw 70, Schiphol Oost, Holland

CENTRAL & SOUTH AMERICA ————— **CANON LATIN AMERICA, INC. SALES DEPARTMENT**
P.O. Box 7022, Panama 5, Rep. of Panama
CANON LATIN AMERICA, INC. REPAIR SERVICE CENTER
P.O. Box 2019, Colon Free Zone, Rep. of Panama

SOUTHEAST ASIA ————— **CANON INC. HONG KONG BRANCH**
5th Floor 2-6, Fui Yiu Kok Street, Tsuen Wan, New Territories, Hong Kong

OCEANIA ————— **CANON AUSTRALIA PTY. LTD.**
22 Lambs Road, Artarmon, Sydney 2064, Australia

